

# INSTALLATION & OPERATION MANUAL

# Atlas PV-10PX & PV-10HPX

10,000 lb. Capacity  
Two-Post Overhead Lift



**Atlas Automotive Equipment**  
[www.atlasautoequipment.com](http://www.atlasautoequipment.com)  
(866) 898-2604

**Read this entire manual before operation begins.**

Record below the following information which is located on the serial number data plate.

Serial No. \_\_\_\_\_

Model No. \_\_\_\_\_

Date of Installation \_\_\_\_\_

# ———— Contents ————

Specifications . . . . .	4
Installation Requirement . . . . .	6
Installation Steps . . . . .	8
Exploded View . . . . .	39
Test Run . . . . .	43
Operation Instructions. . . . .	45
Maintenance Schedule. . . . .	46
Trouble Shooting . . . . .	47
PV-10PX and PV-10HPX Parts List . . . .	48
Warranty . . . . .	53

# Specifications

---

## Clear-Floor Direct-Drive Model Features

### Model PV-10PX & PV-10HPX (See Fig. 1)

- Direct drive hydraulic cylinder design, minimizes the lift wear parts and breakdown ratio
- Dual hydraulic cylinders, designed and made on ANSI standards, utilizing NOK oil seal in cylinder
- Self- lubricating UHMW Polyethylene sliders and bronze bush
- Single-point safety release with dual safety design
- Clear-floor design, provides non-obstructed floor use
- Overhead safety shut-off device prevents vehicle damage
- Standard adjustable heights accommodates variety of ceiling heights



Fig. 1

# Model PV-10PX/ PV-10HPX Specifications

Model	Style	Lifting Capacity	Lifting Time	Lifting Height	Overall Height	Overall Width	Width Between columns	Minimum Pad Height	Motor
PV-10PX	Clear-floor Direct drive	4.5 T 10,000 lbs	55S	1842-2112mm 72 1/2"–83 1/8"	3635/3735mm 143 1/8" / 147"	3492mm 137 1/2"	2800mm 110 1/4"	115 mm 4 1/2"	3.0HP
PV-10HPX	Clear-floor Direct drive	4.5 T 10,000 lbs	55S	1842-2112mm 72 1/2"–83 1/8"	3812/4245/4345mm 150"/167 1/8"/171"	3492mm 137 1/2"	2800mm 110 1/4"	115mm 4 1/2"	3.0 HP

## Arm Swings View For Model PV-10PX & PV-10HPX

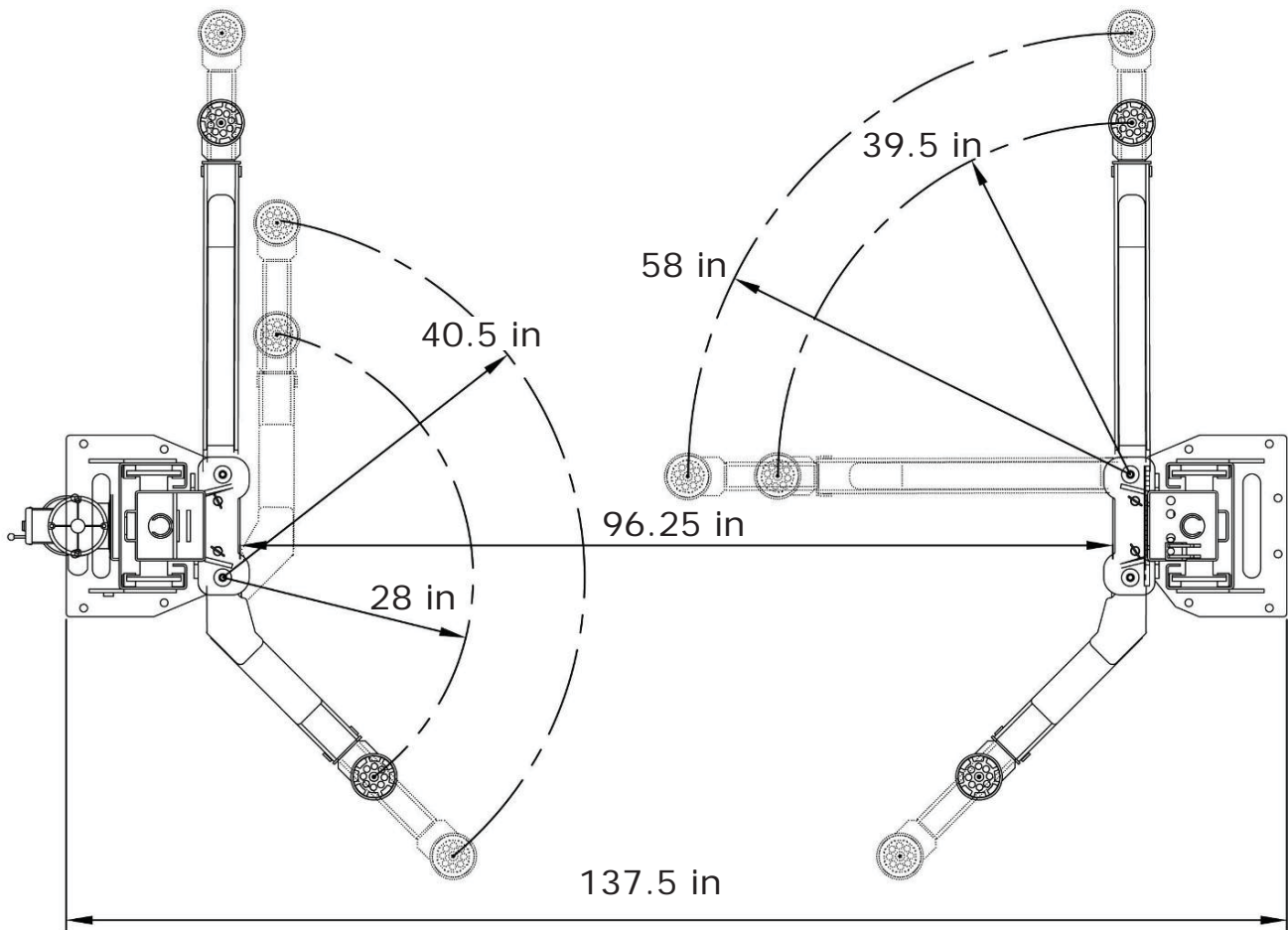

Fig. 2

# Installation Requirement

---

## Tools Required

Rotary Hammer Drill (3/4in bit)



Carpenter's Chalk



Hammer



Screw Drivers



4 Foot Level



Tape Measure (25ft)



Crescent Wrench (12")



Pliers



Ratchet & Socket (28mm)



Allen Head Wrench (3mm, 5mm, 8mm)



Wrench set (mm)  
(10#, 13#, 14#, 15#, 17#, 19#, 24#, 27#, 30#)



Vise Grips



Fig. 3

## Concrete Specifications (See Fig. 4)

Concrete specifications must be followed accordingly.

**Failure to do so may result in lift and/or vehicle falling.**

1. Concrete must have 4 inches minimum and must be totally cured before lift installation.
2. Concrete must be in good condition and must have a test strength 3,000psi minimum.
3. Floors must be level with no cracks or holes.

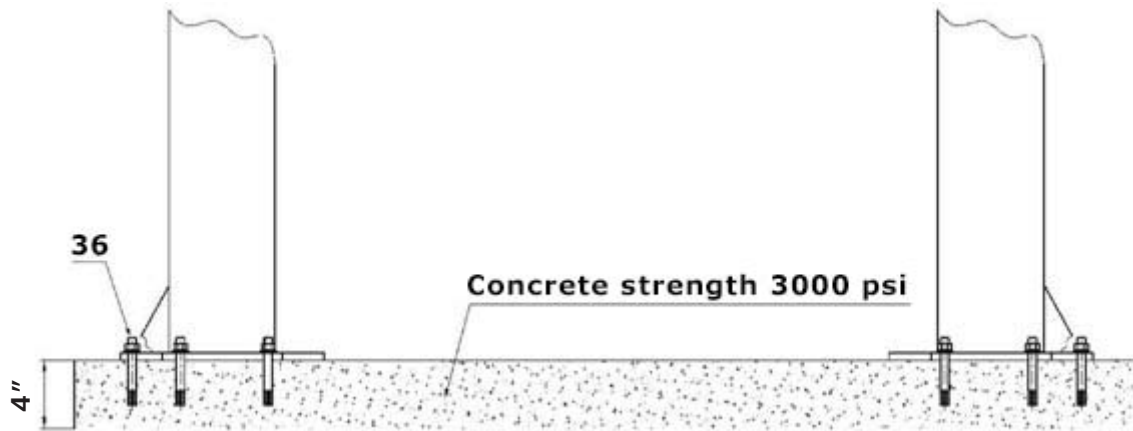

Fig. 4

## Power Supply

220 volt single phase motor on a 30 amp breaker with minimum of 10 gauge wire. Operating voltage range is 208v-230v.

# Installation Steps

---

## A. Location of installation

Check and ensure the installation location (concrete, layout, space size etc.) is suitable for lift installation.

## B. Use a carpenter's chalk line to establish installation layout of base plate (See Fig. 5).

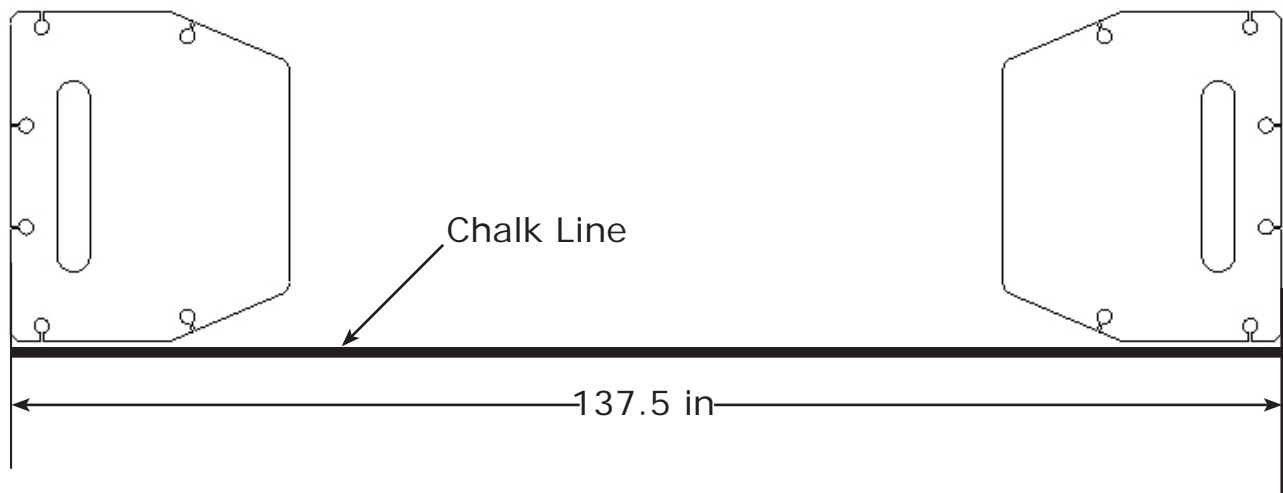

Fig. 5

## C. Check the parts before assembly.

1. Packaged lift and hydraulic power unit (See Fig. 6).



Fig. 6



2. Move aside the lift aside with a fork lift or hoist, and open the outer packing carefully (See Fig. 7).

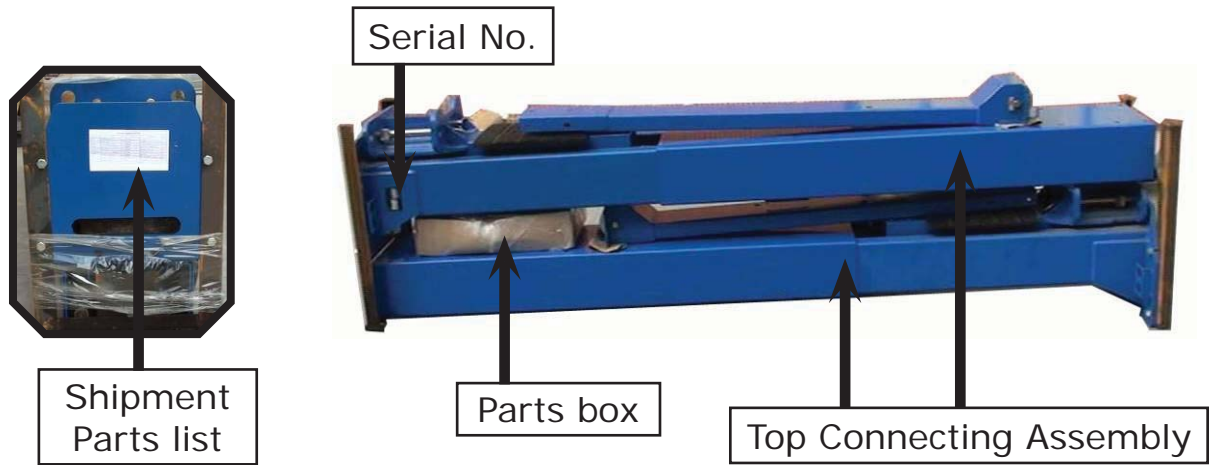

**Fig. 7**

3. Remove the top connecting assembly and parts box (See Fig. 8).



**Fig. 8**

4. Lift the upper column with a fork lift or hoist and loosen the bolts on the upper package stand. Remove the upper column and take out the parts in the bottom column (See Fig. 9).



**Fig. 9**

5. Lift the lower column with a fork lift or hoist, remove the package stand. Remove the lower column and remove the parts in the inner column (See Fig. 10).

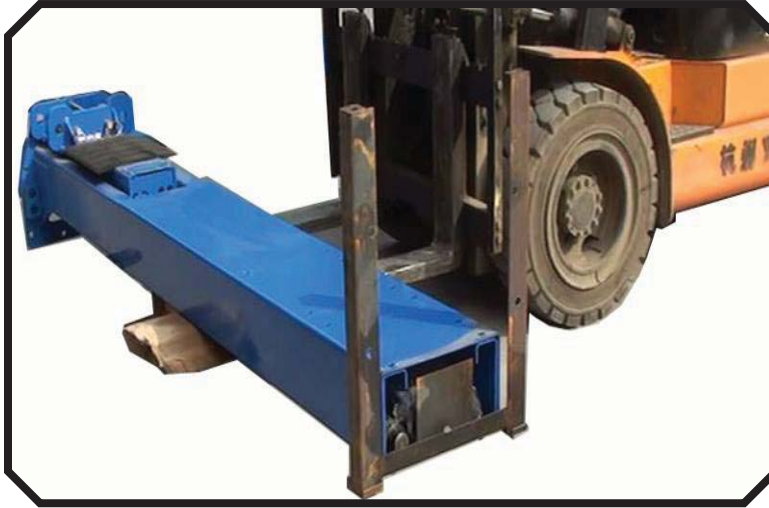

**Fig. 10**

6. Move aside the parts and check the parts according to the shipment parts list (See Fig. 11).



**Fig. 11**

7. Open the parts box and check the parts according to parts box list (See Fig. 12).



Fig. 12

8. Check the parts in the parts bag 1 according to parts bag list (See Fig. 13).

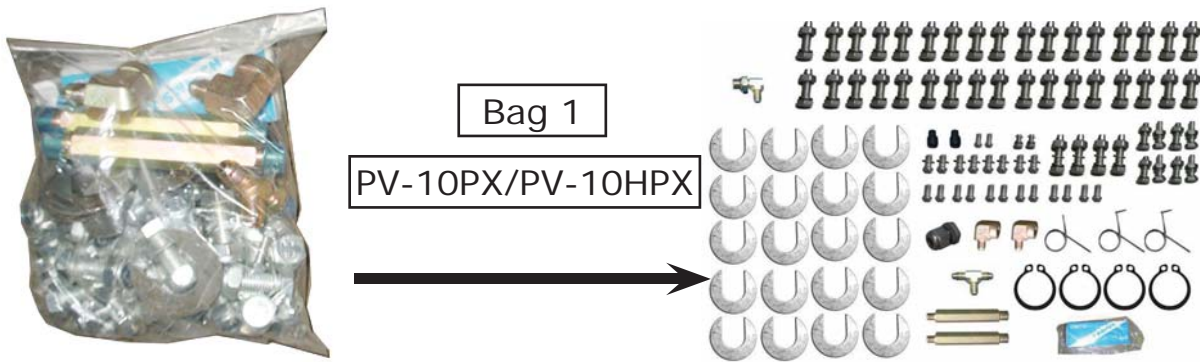

Fig. 13

9. Check the parts in the parts bag 2 according to parts bag list (See Fig. 14).

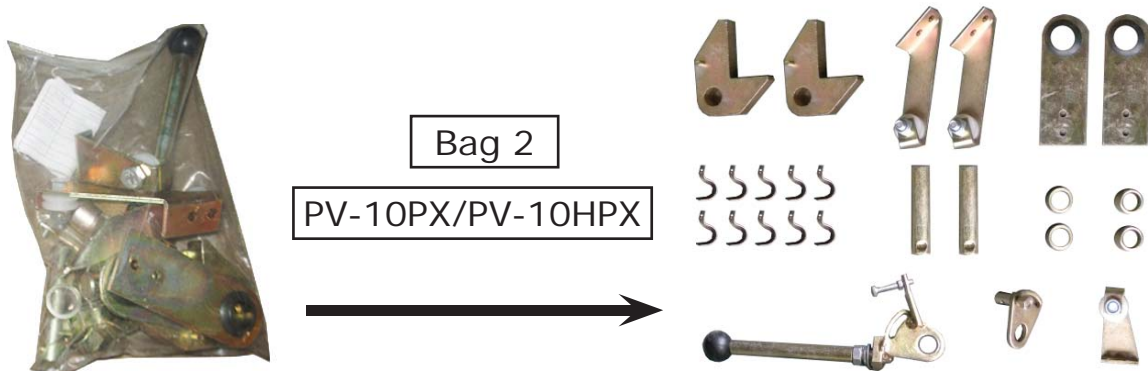
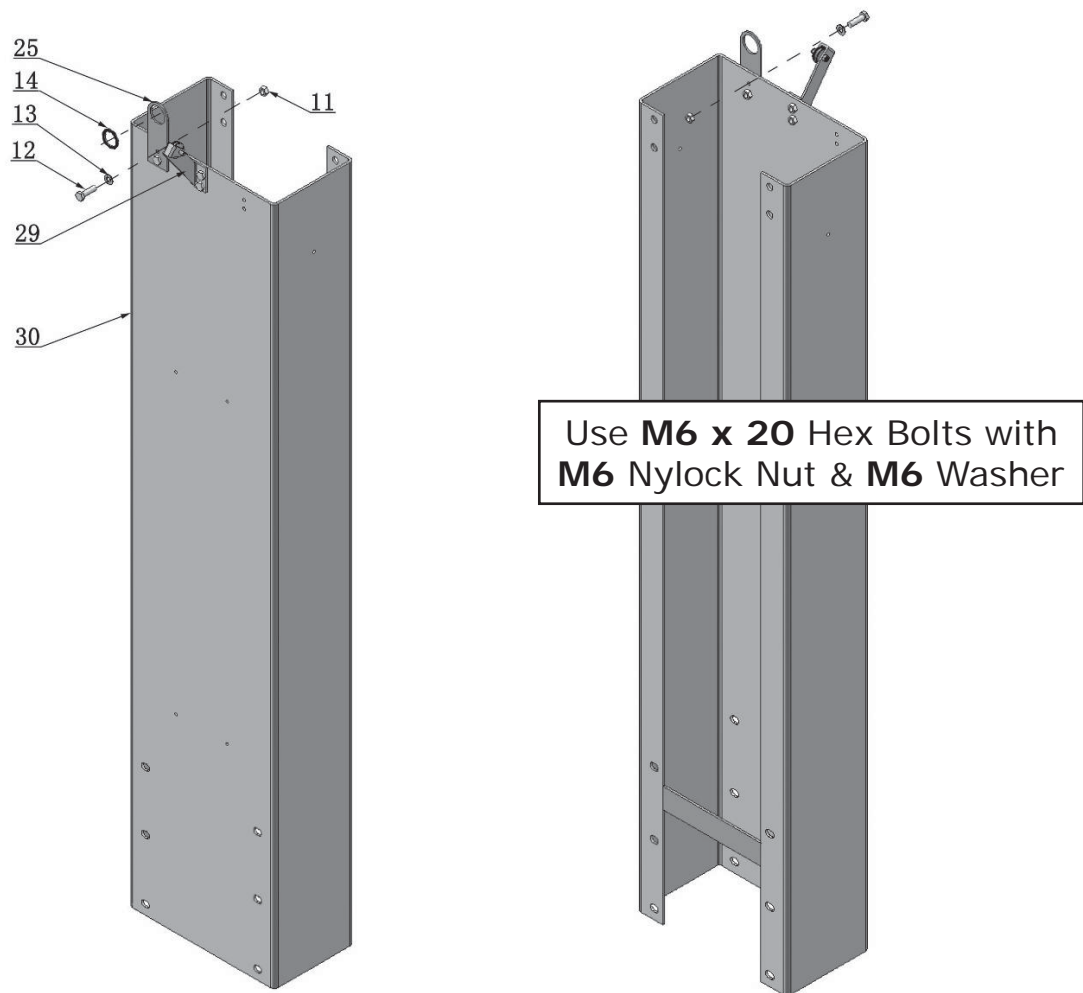

Fig. 14

**D. Install the hydraulic hose and lock release cable brackets on the extension columns (See Fig. 15).**



**Fig. 15**

## E. Install hydraulic cylinder

Connect the extended straight fitting and 90° fitting. Install the cylinders inside the carriages (See Fig. 16).

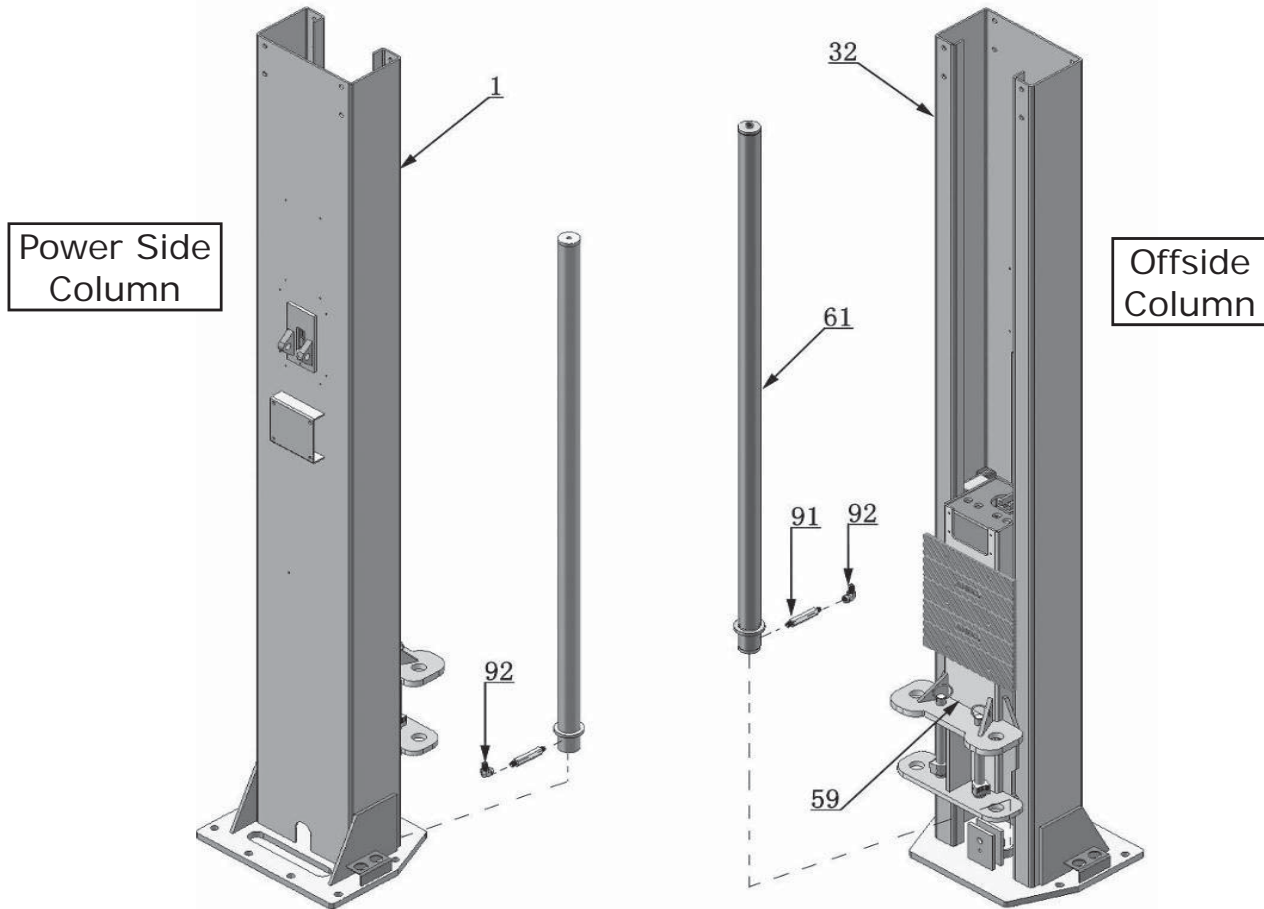

Use Teflon tape to seal pipe threads.  
Do not use teflon tape on hydraulic hose ends.

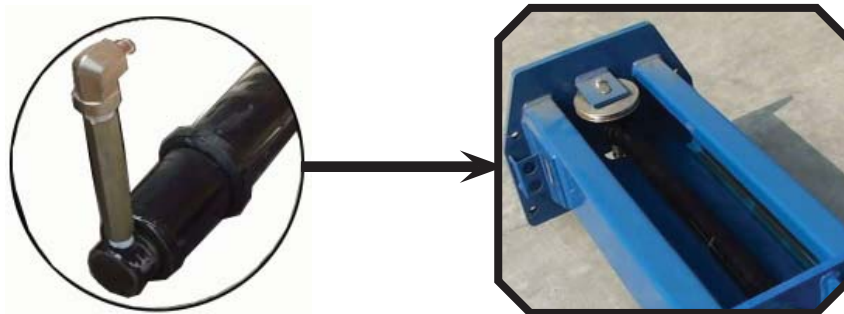

Fig. 16

## F. Install columns

Lay down the two columns on the installation site parallel of each other. Position the power side column according to the actual installation site. This lift is designed with 2 sectional columns. Adjust the height according to your ceiling height.

### For model PV-10PX

1. When the ceiling height is less than 3750mm (147 5/8"), connect the sectional columns with the upper holes (**See Fig. 17**).

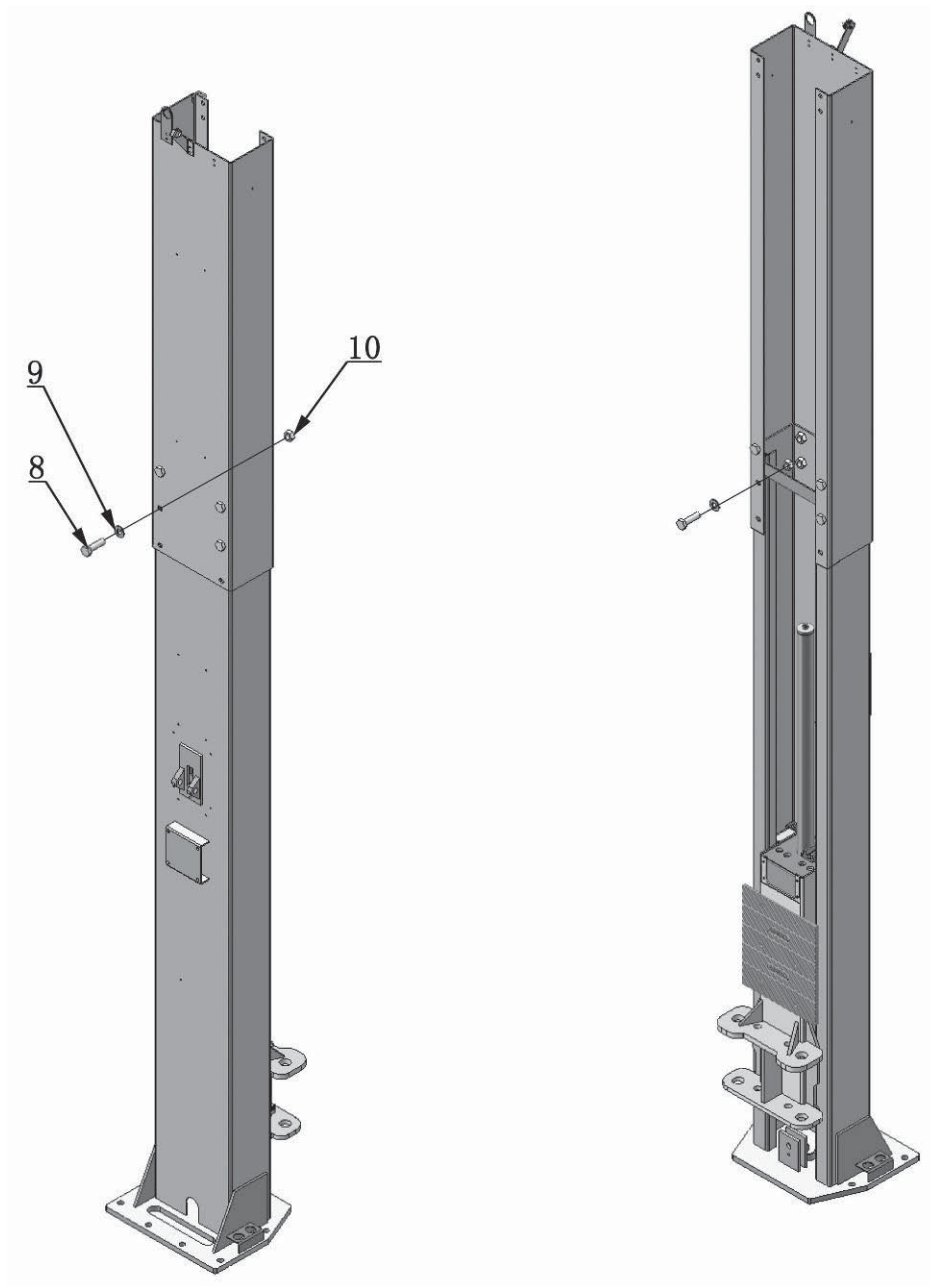

**Fig. 17 - Low Setting**



2. When the ceiling height is over 3750mm (147 5/8"), connect the sectional columns with the lower holes (**See Fig. 18**).

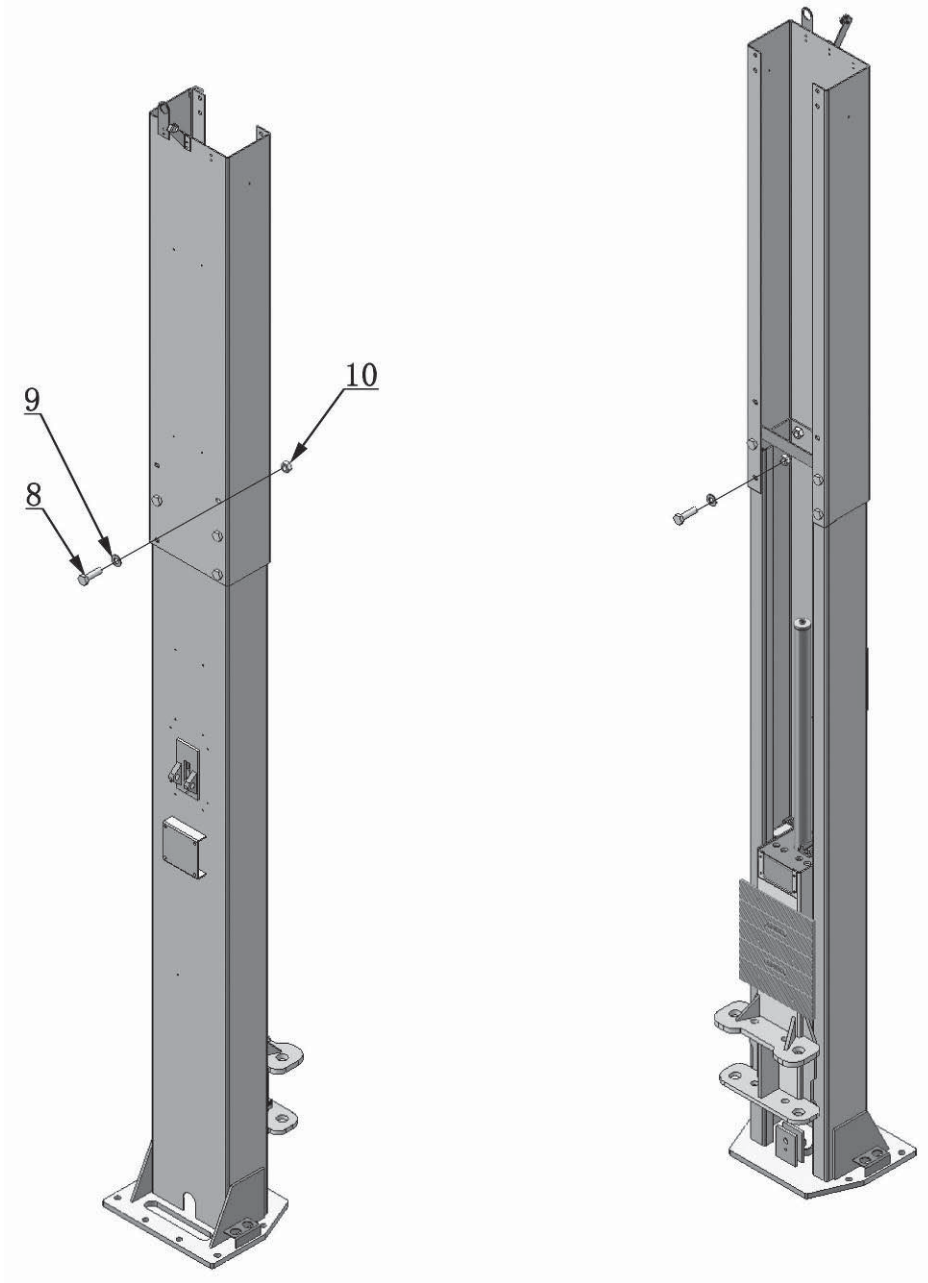

**Fig. 18 - High Setting**

## For model PV-10HPX

1. When the ceiling height is between 4250mm (167 3/8") and 4350mm (171 1/4"), connect the sectional columns with the middle holes (**See Fig. 19**).

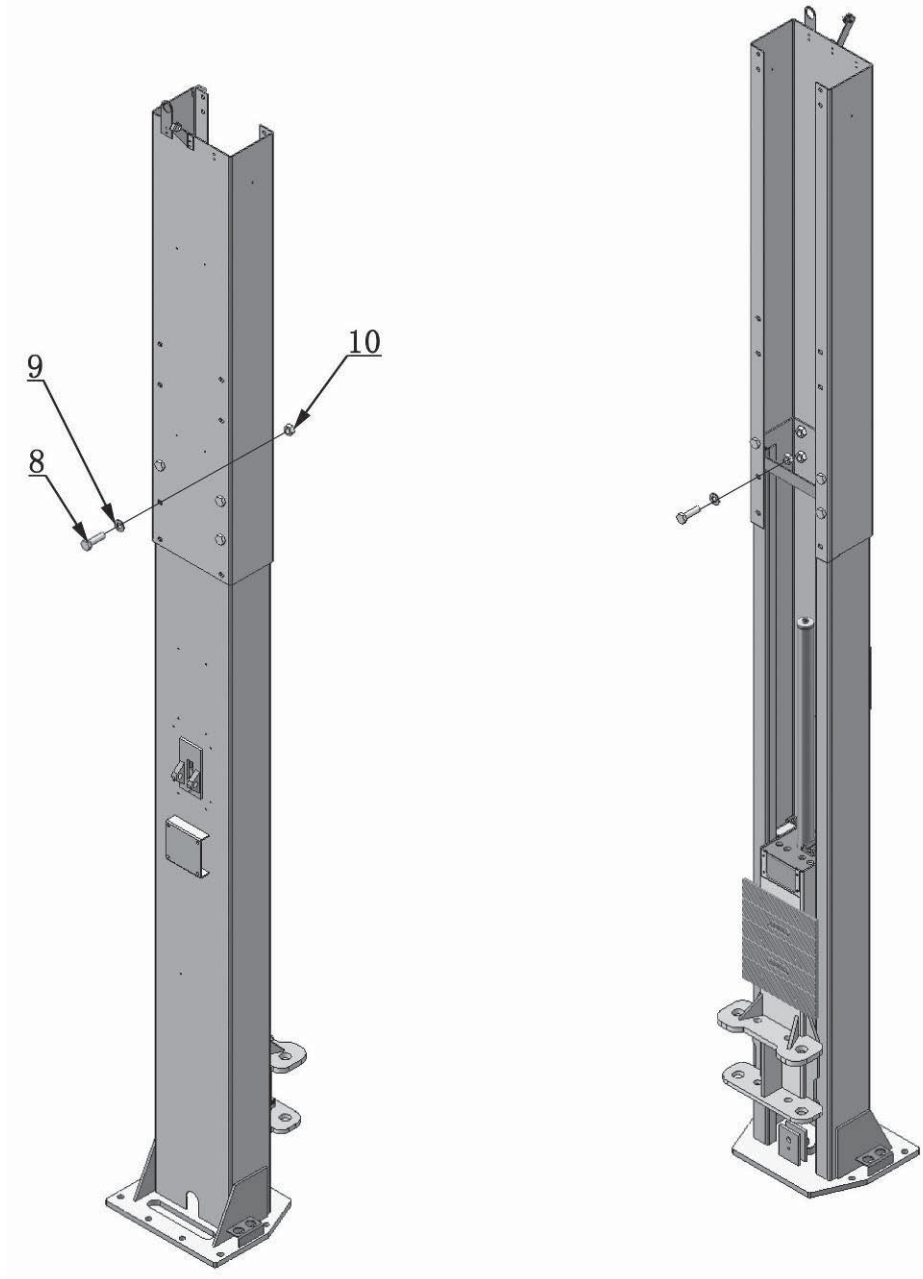

**Fig. 19 - Low Setting**



2. When the ceiling height is over 4350mm (171 1/4"), connect the sectional columns with the lower holes (**See Fig. 20**).

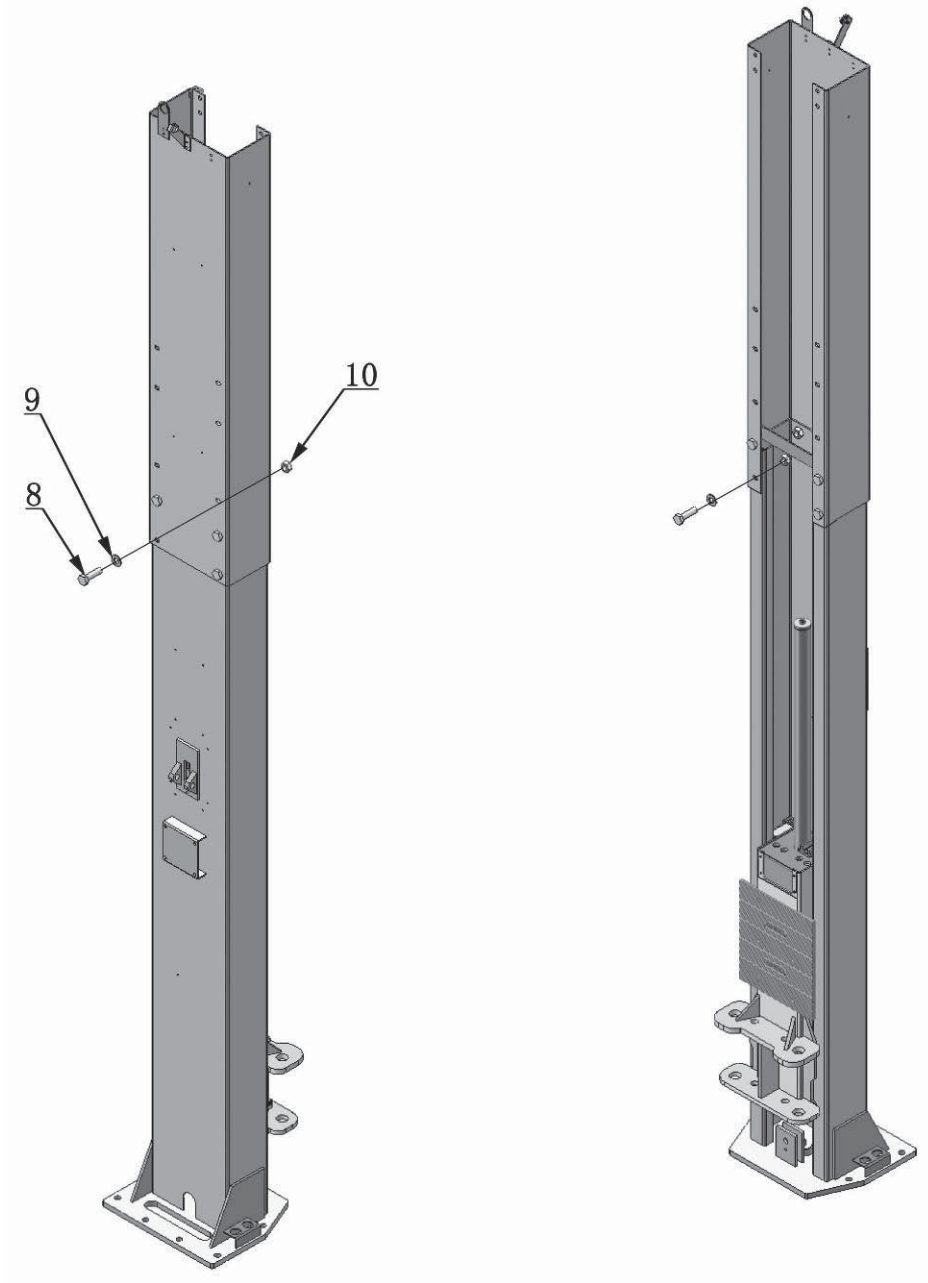

**Fig. 20 - High Setting**

## G. Position posts

Position the columns upright on the installation layout. Position the offside column parallel to the power side column at the approximate overall width (137 1/2"). Install the overhead cross beam. Do not drill holes for anchor bolts until overhead cross beam has been installed.

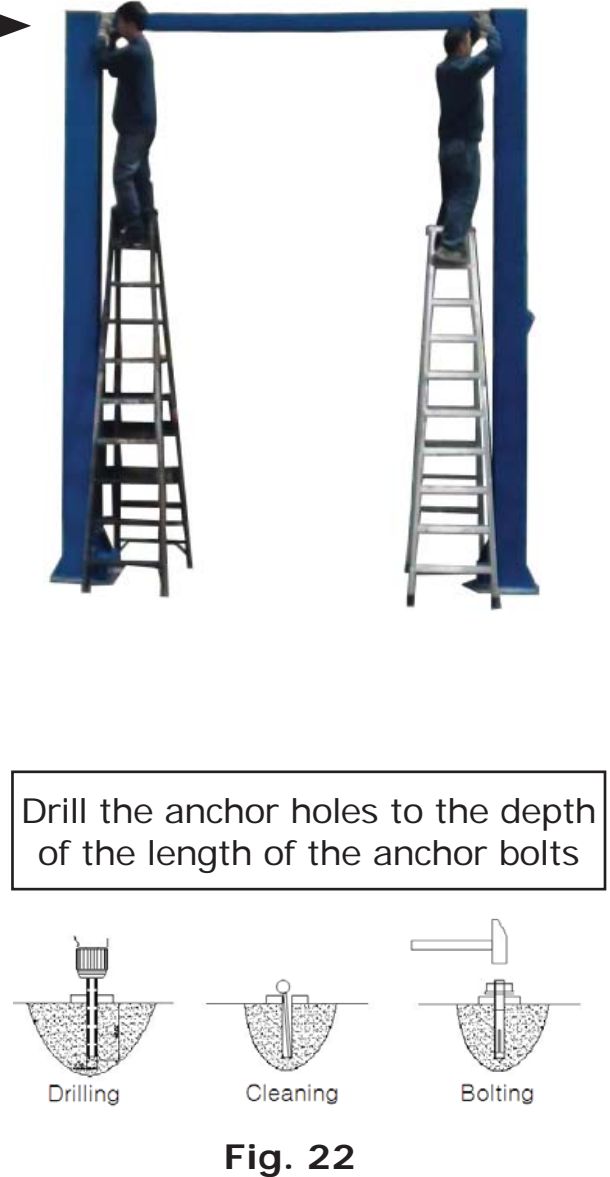
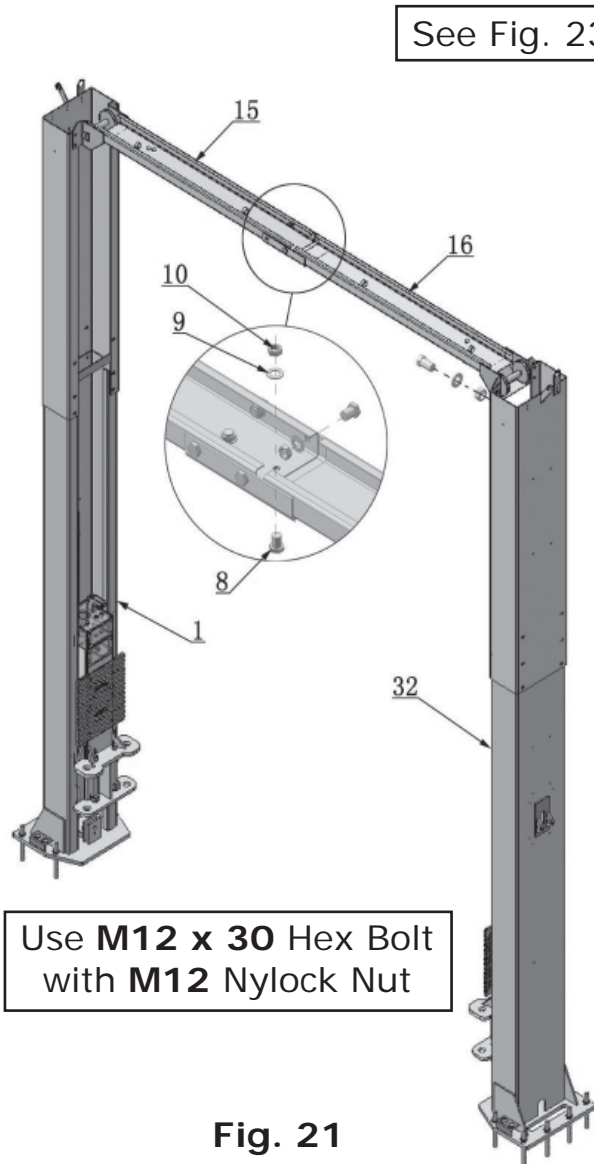

Install the anchor bolts. Check the posts for plumb with level bar, and adjust with the horseshoe shims if the columns are not plumb. Do not tighten the anchor bolts.

## H. Install overhead top beam

1. With help of the hook of top beam, put one side of top beam on top of the extension column and connect the top beam to extension column by bolts, tighten the bolts. Then assemble the connecting bracket (**See Fig. 23**).

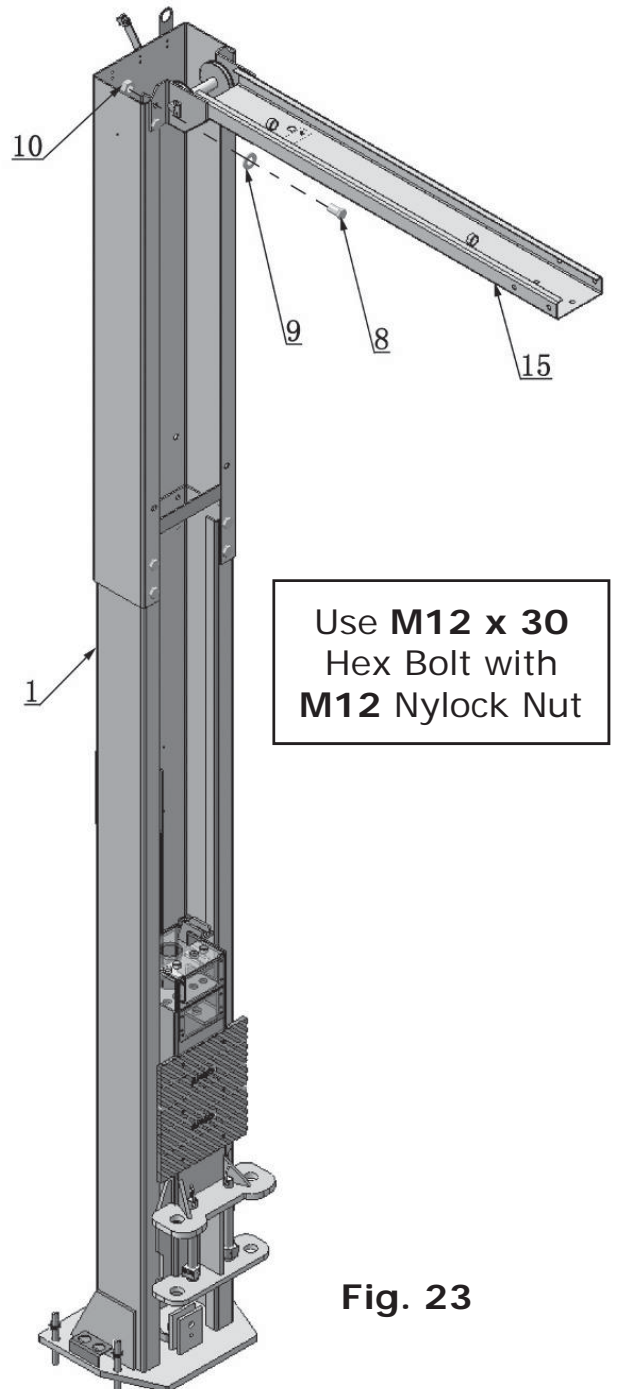
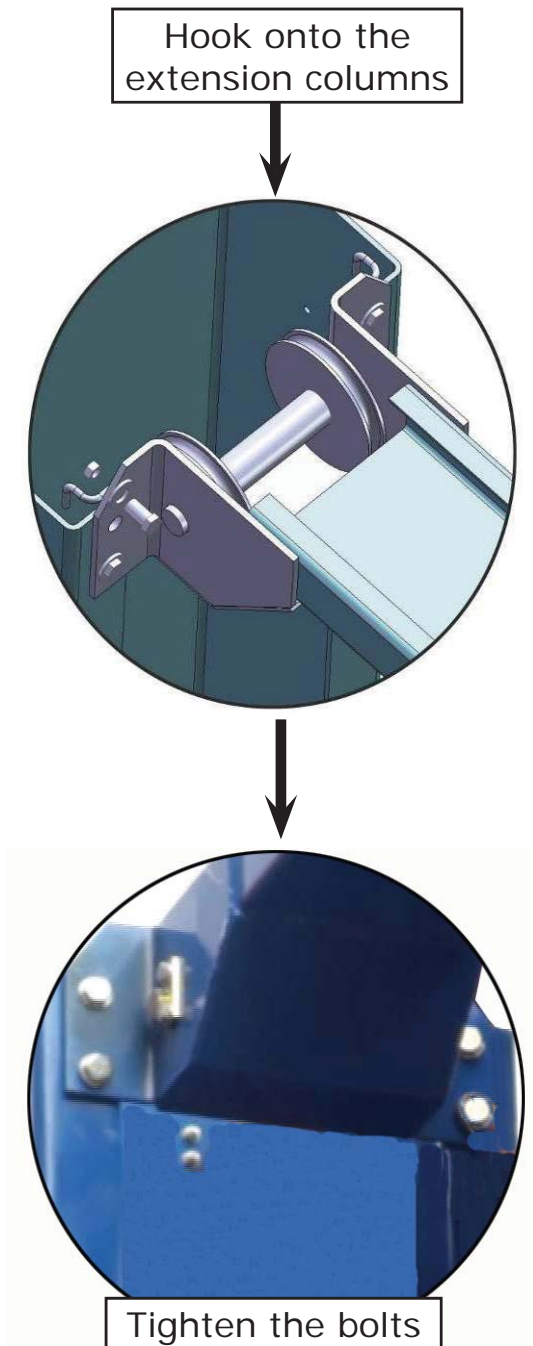

**Fig. 23**

2. Assemble overhead top beam and tighten the anchor bolts (See Fig. 24).

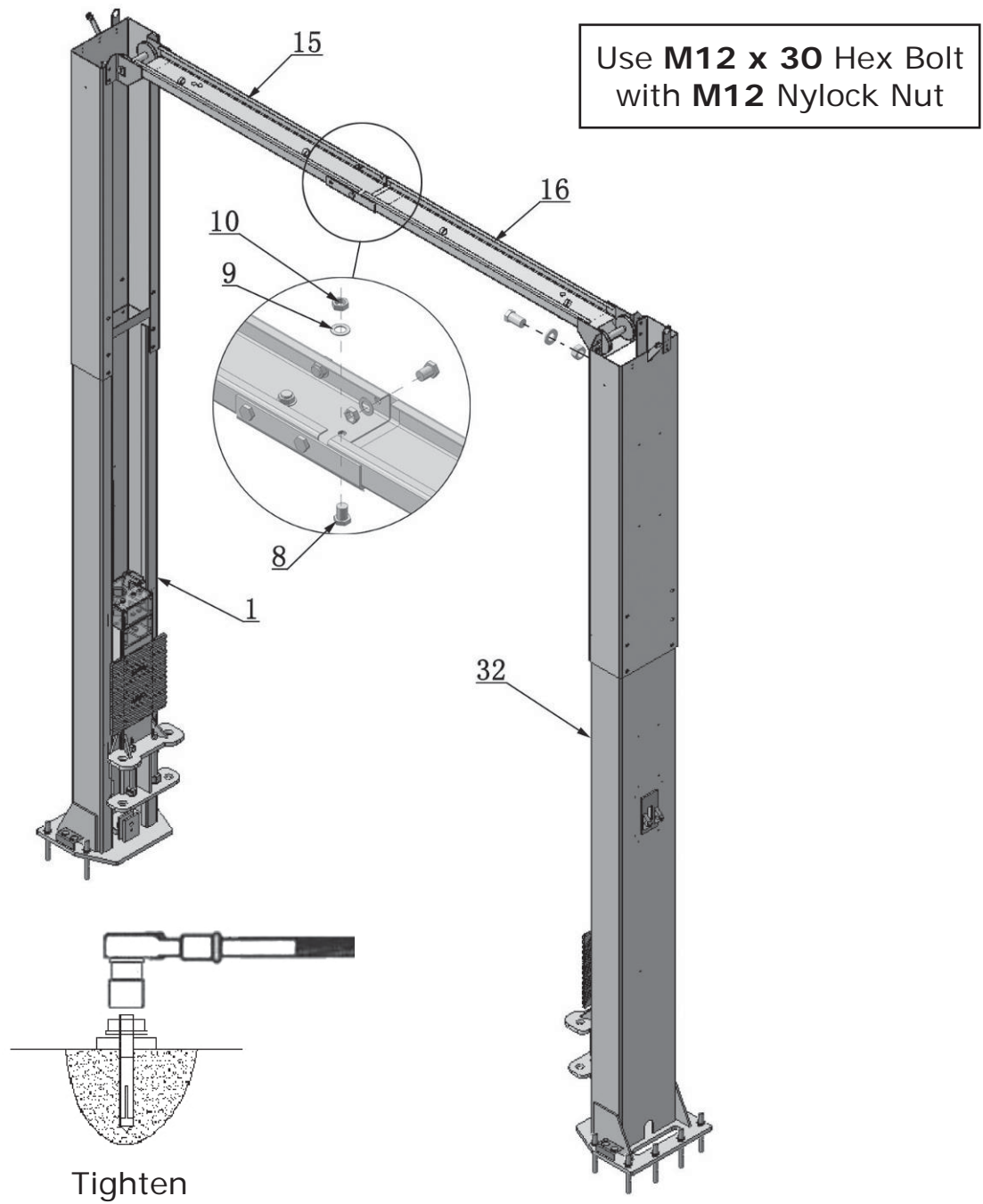
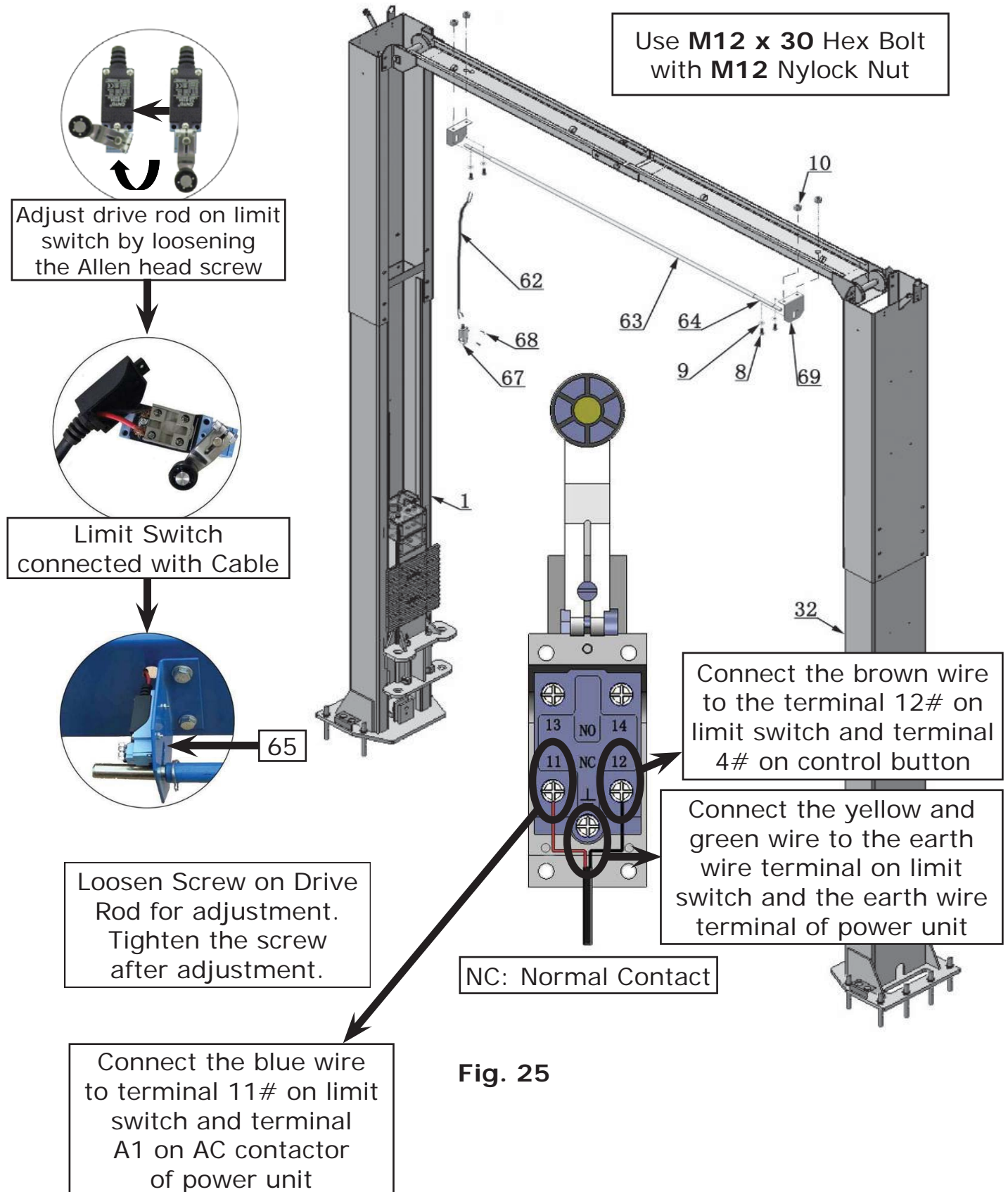
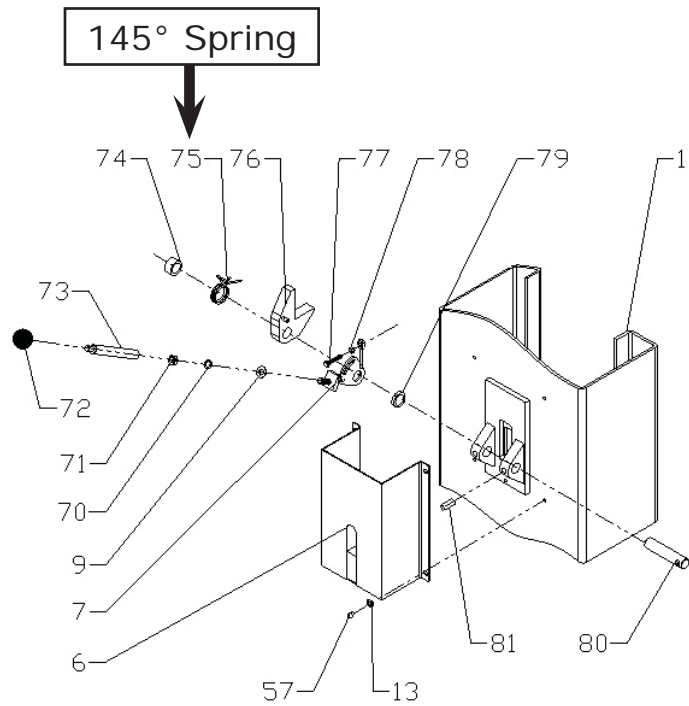
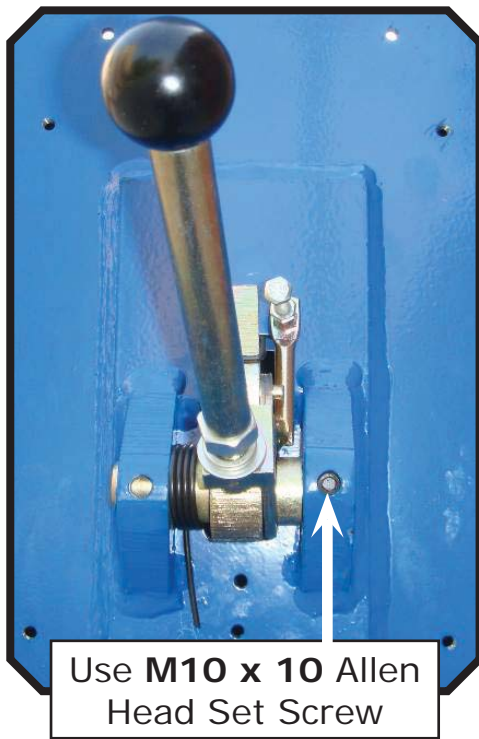

Fig. 24

# I. Installing the limit switch control bar and limit switch (See Fig. 25).



## J. Install safety device (See Fig. 26 & Fig. 27).



**Fig. 26 - Power side safety device**

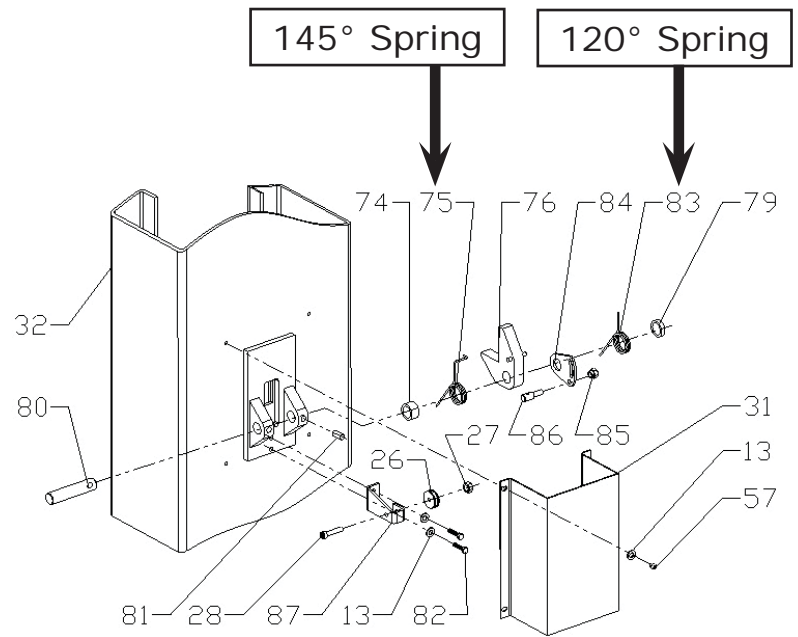
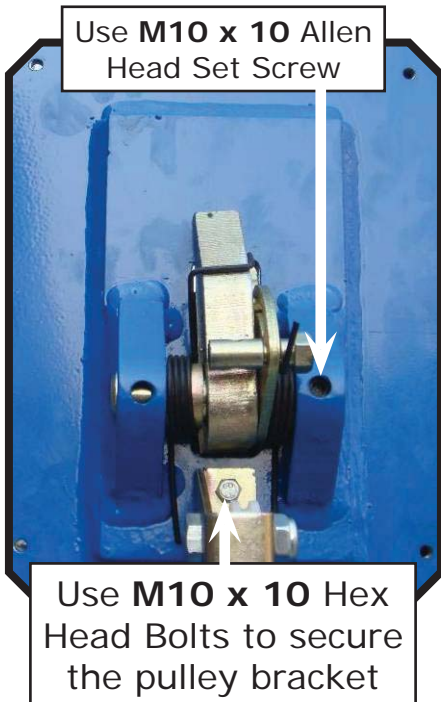

**Fig. 27 - Offside safety device**



**K. Lift the carriages up manually and lock them on the 1st set of locks (See Fig. 28).**

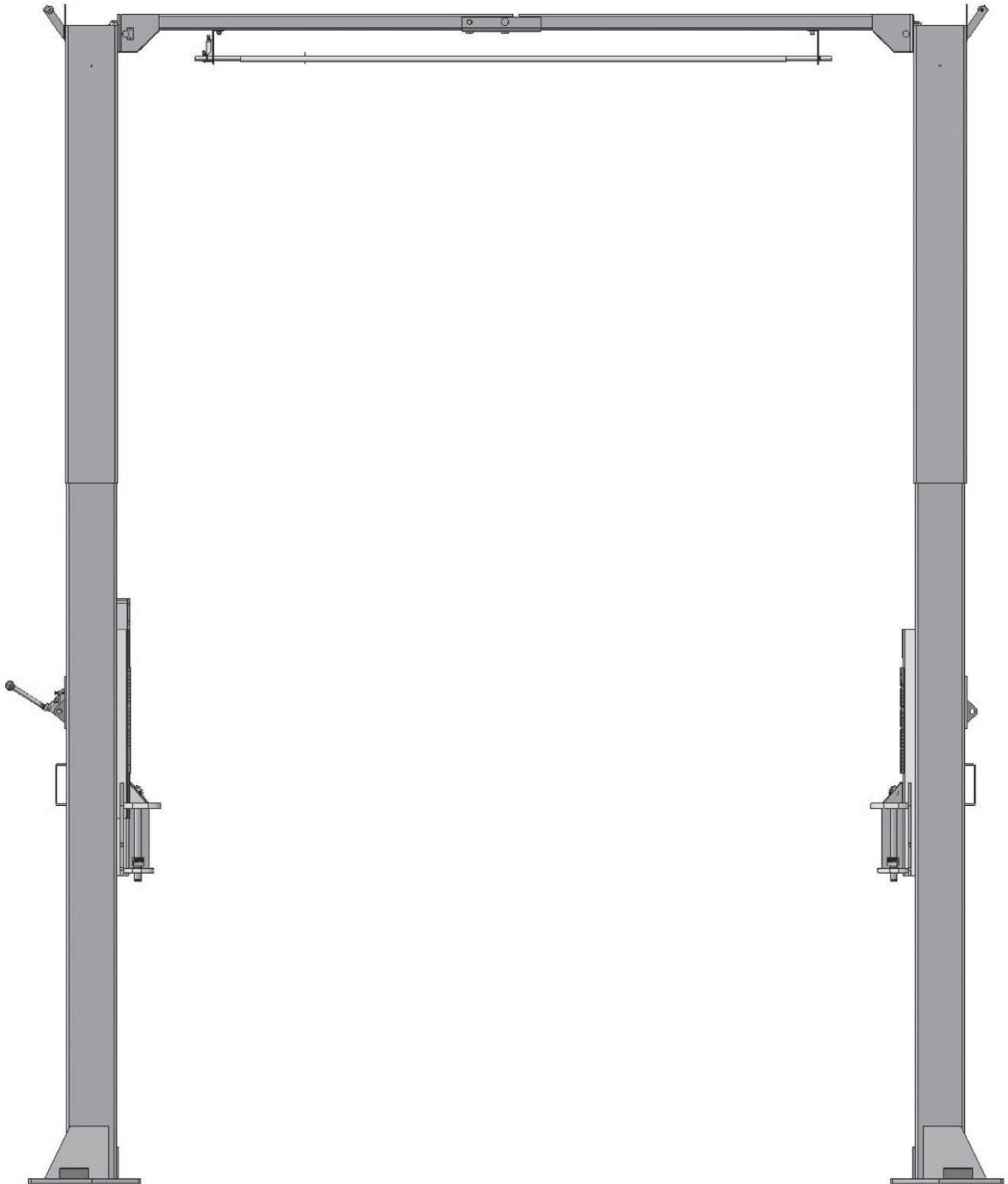

**Fig. 28**

## L. Install cables

### For model PV-10PX

1. **High setting cable connection (See Fig. 29).** For a ceiling height over 3750mm (147 5/8")

1.1 Remove the carriages' plastic covers, the cable passes through from the bottom of the carriages and is pulled out from the opening of carriages, then install the two cable nuts (See Fig. 29).

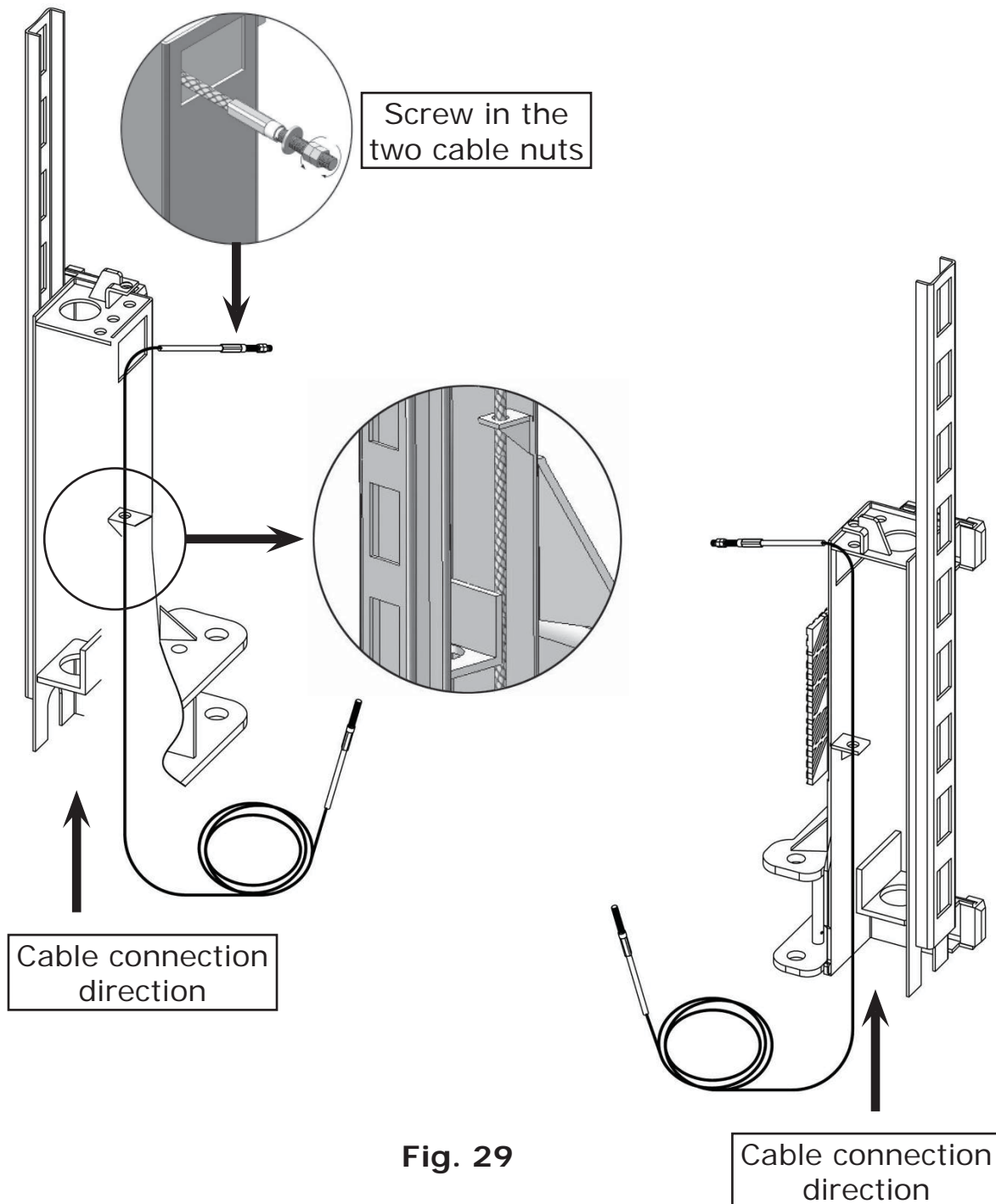



1.2 Connecting cable for high setting (See Fig. 30).

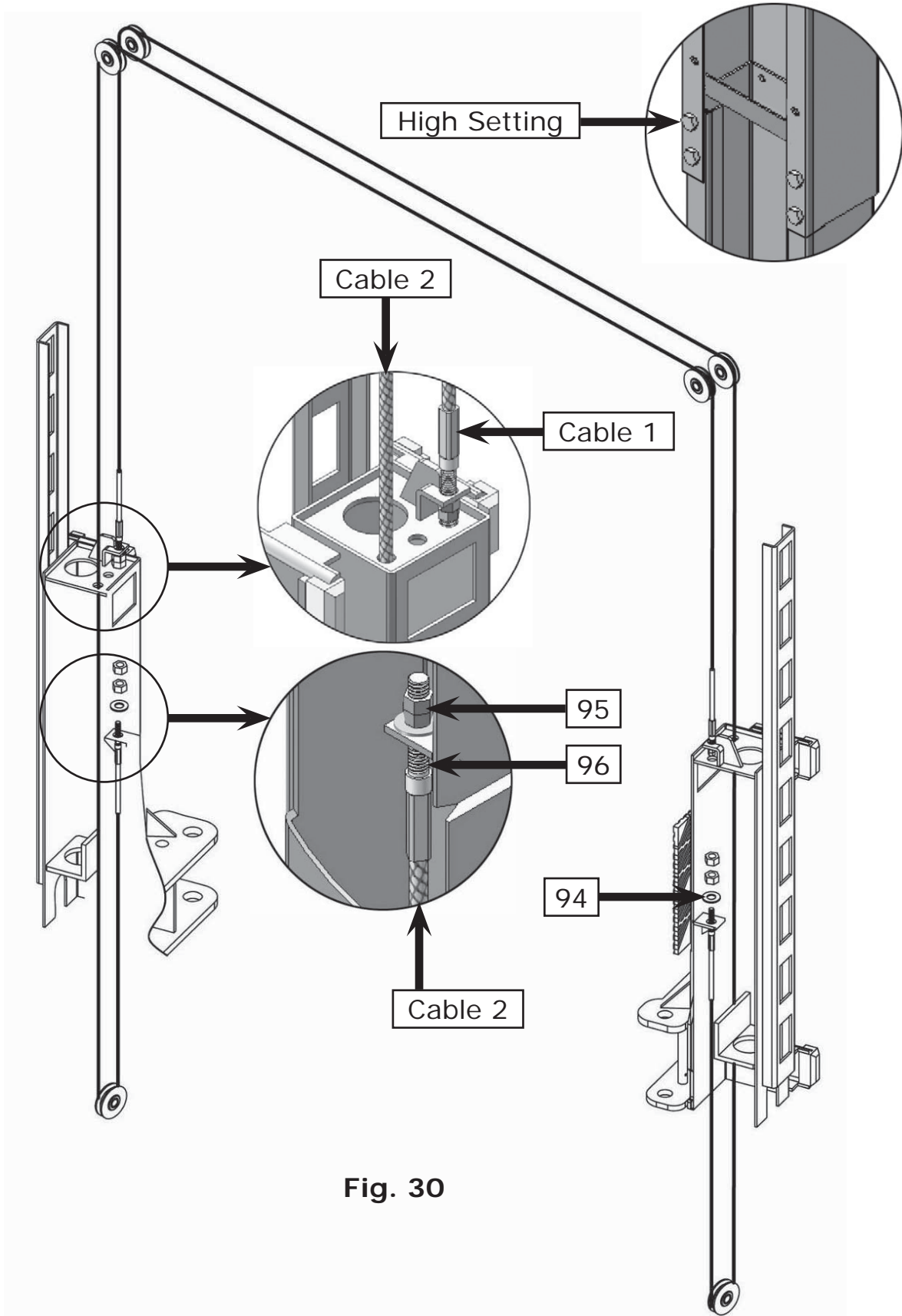
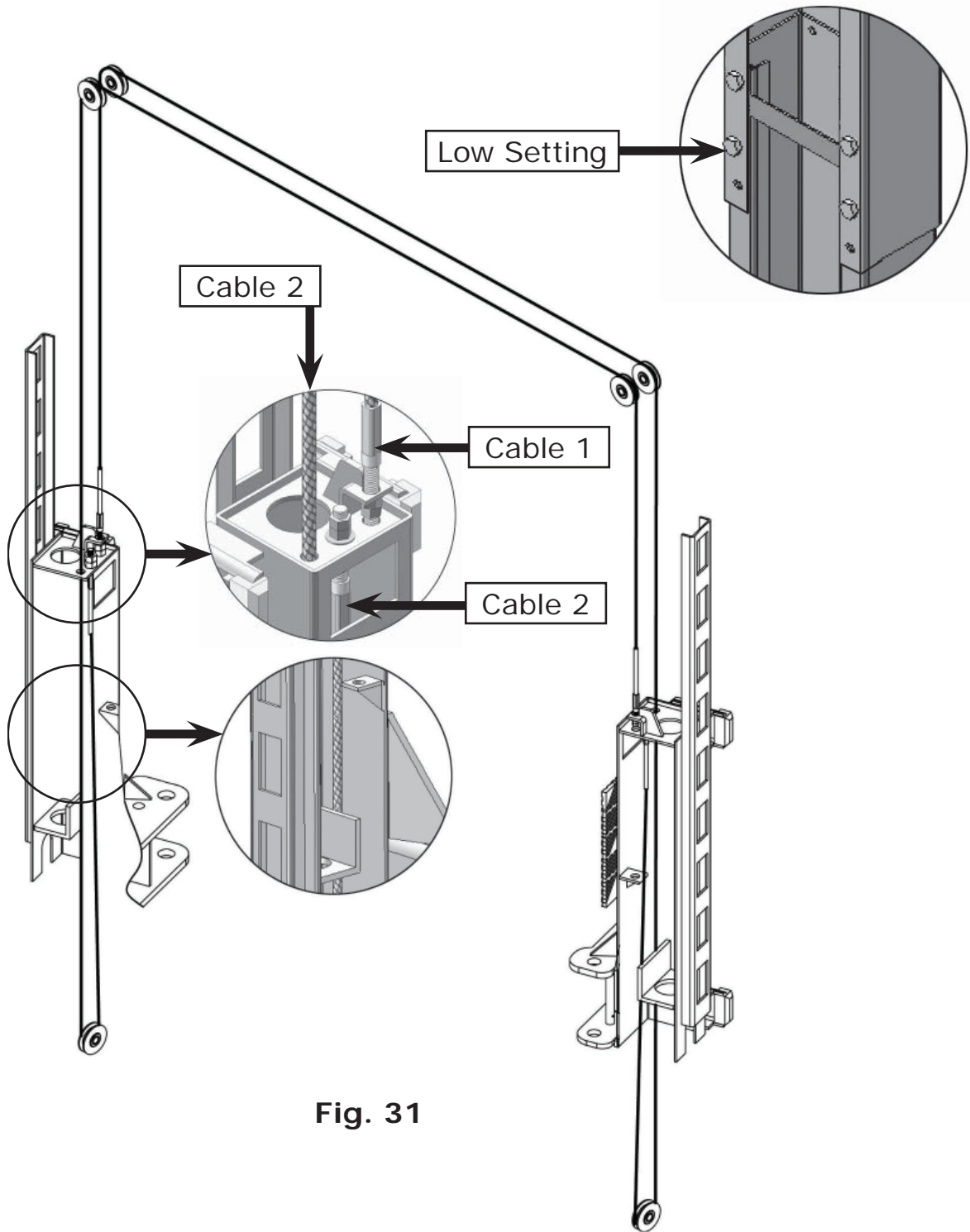

Fig. 30

2. **Low setting cable connection (See Fig. 31).** For a ceiling height less than 3750mm (147 5/8")

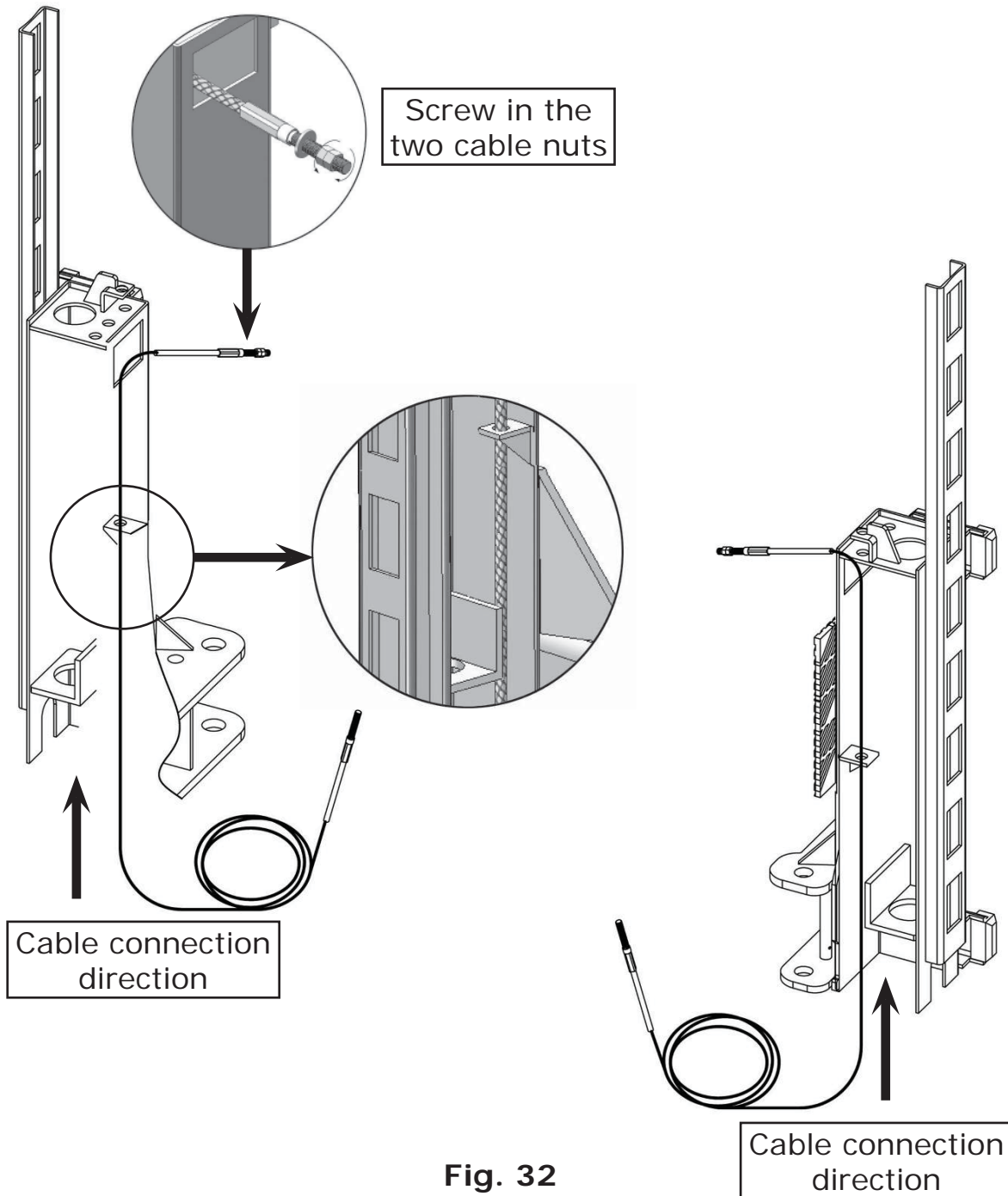

**Fig. 31**

## For model PV-10HPX

### 1. High setting cable connection. For a ceiling height over 4350mm (171 1/4")

1.1 Remove the carriages' plastic covers, the cable passes through from the bottom of the carriage and is pulled out from the opening of the carriages, then install the two cable nuts (See Fig. 32).



1.2 Connecting cable for high setting (See Fig. 33).

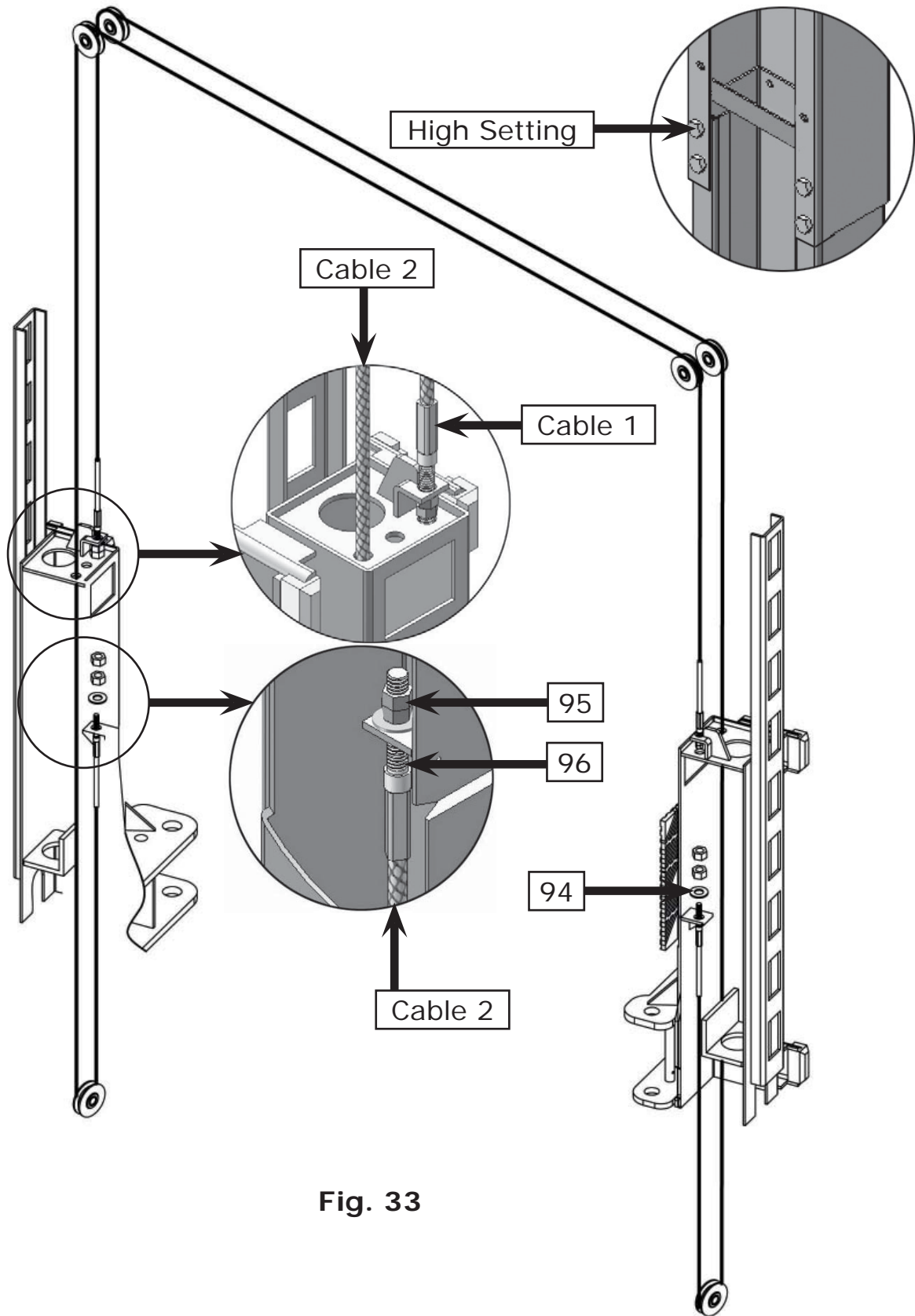
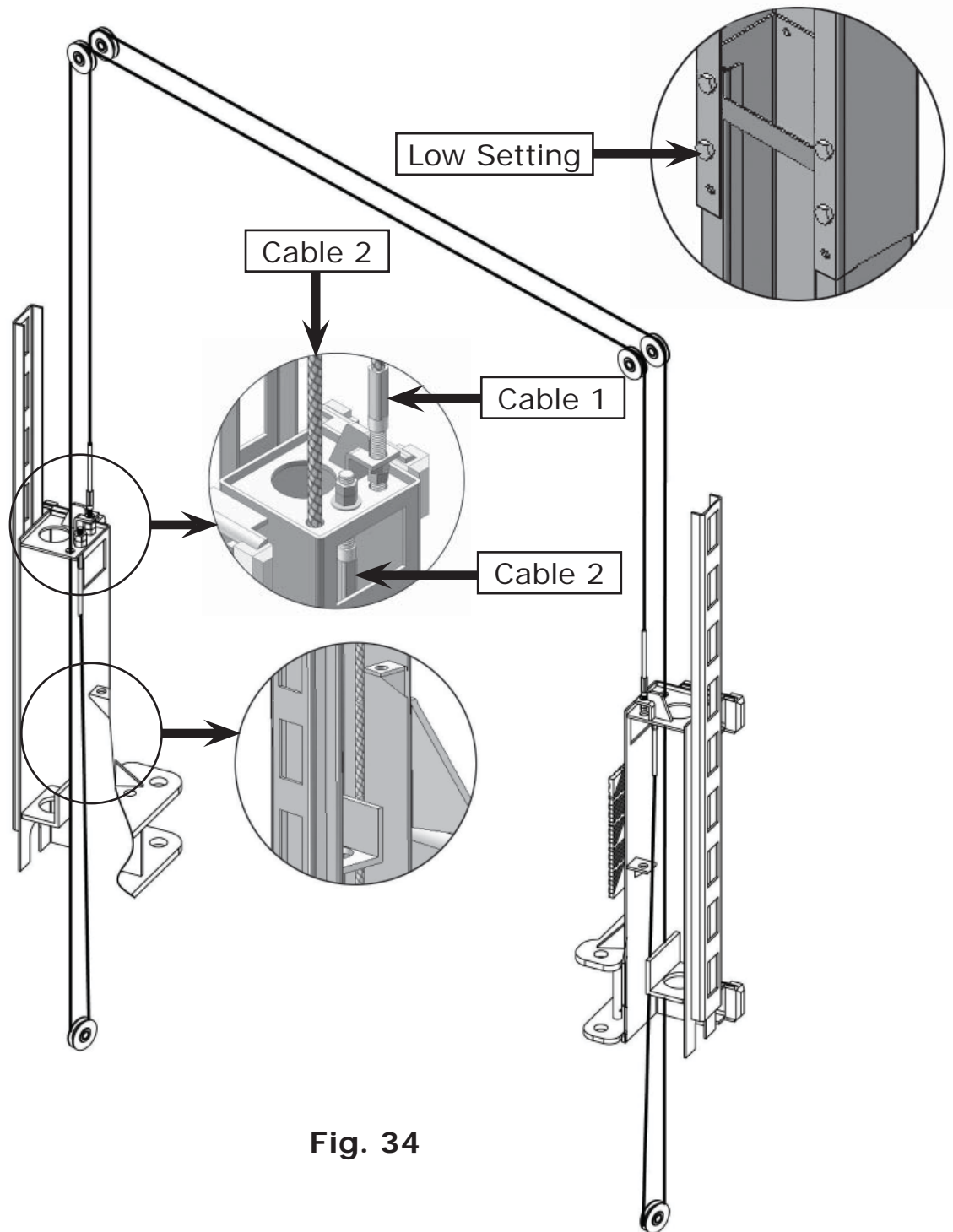

Fig. 33

2. **Low setting cable connection (See Fig. 34).** For a ceiling height between 4250mm (167 3/8") and 4350mm (171 1/4").



**Fig. 34**

3. **Special low setting cable connection PV10PX.** For a ceiling height between 3820mm (150 3/8") to 4250mm (167 3/8"). This setting requires the optional short cables (See Fig. 35).

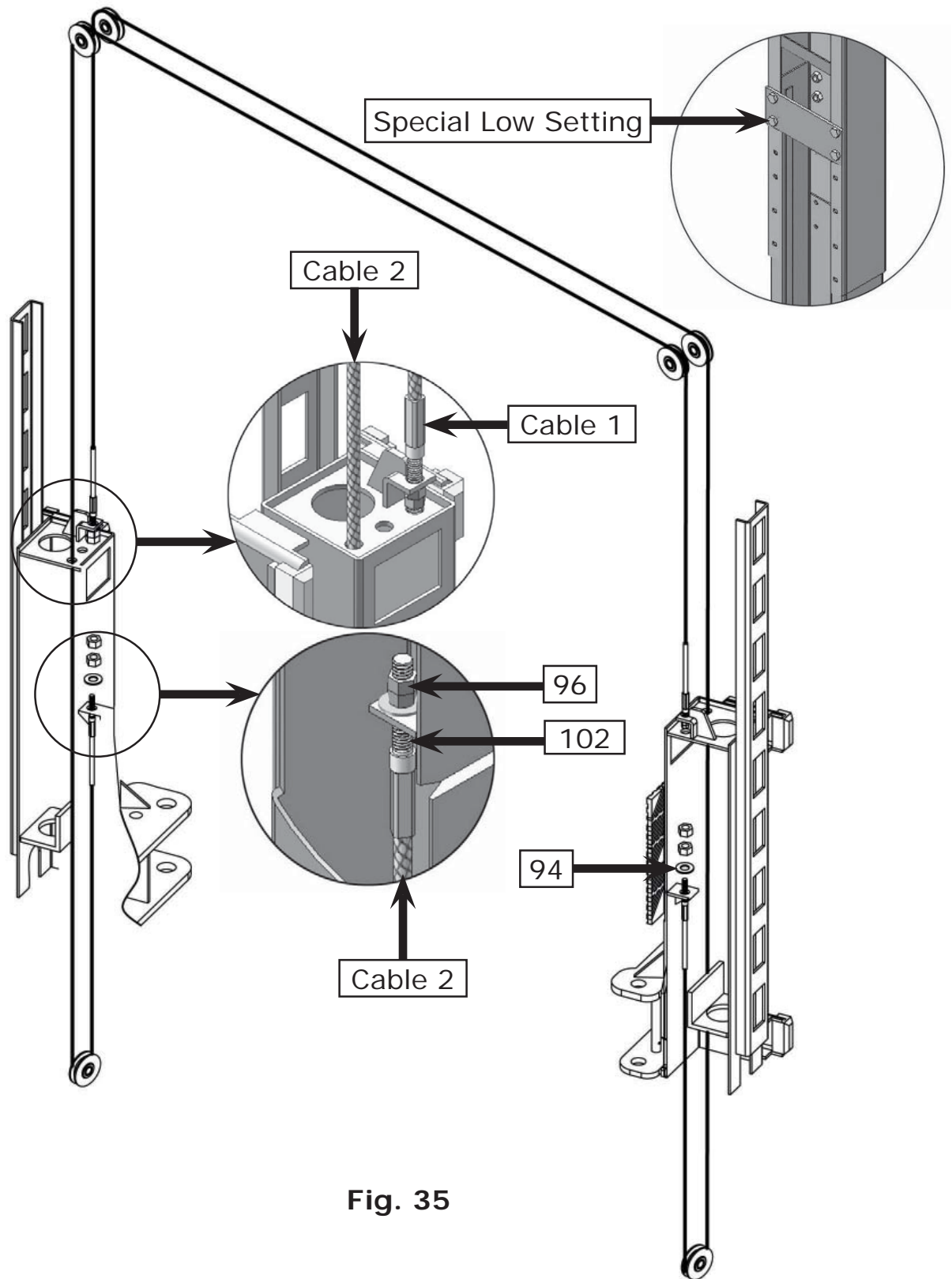

Fig. 35

## M. Install power unit (See Fig. 36)

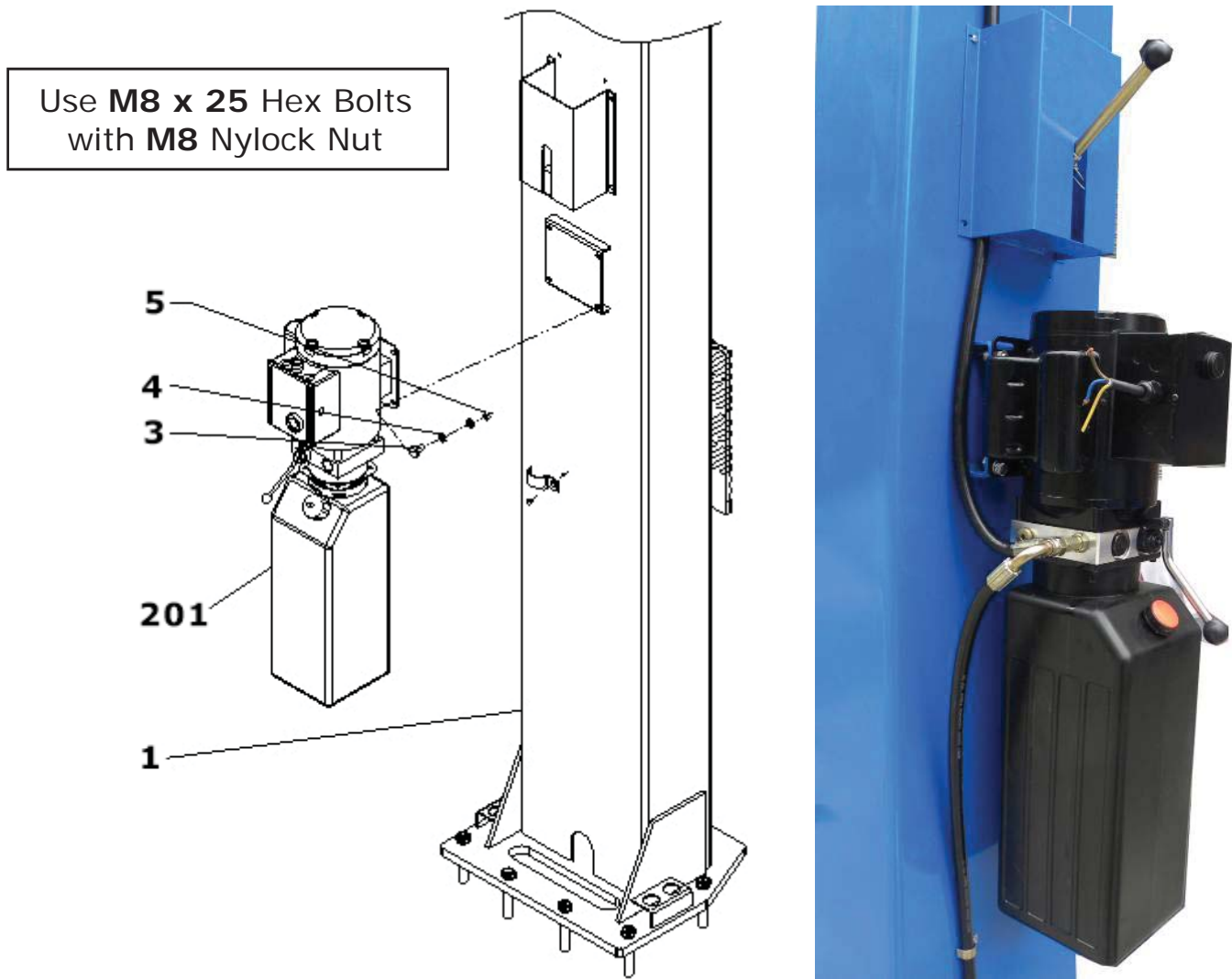
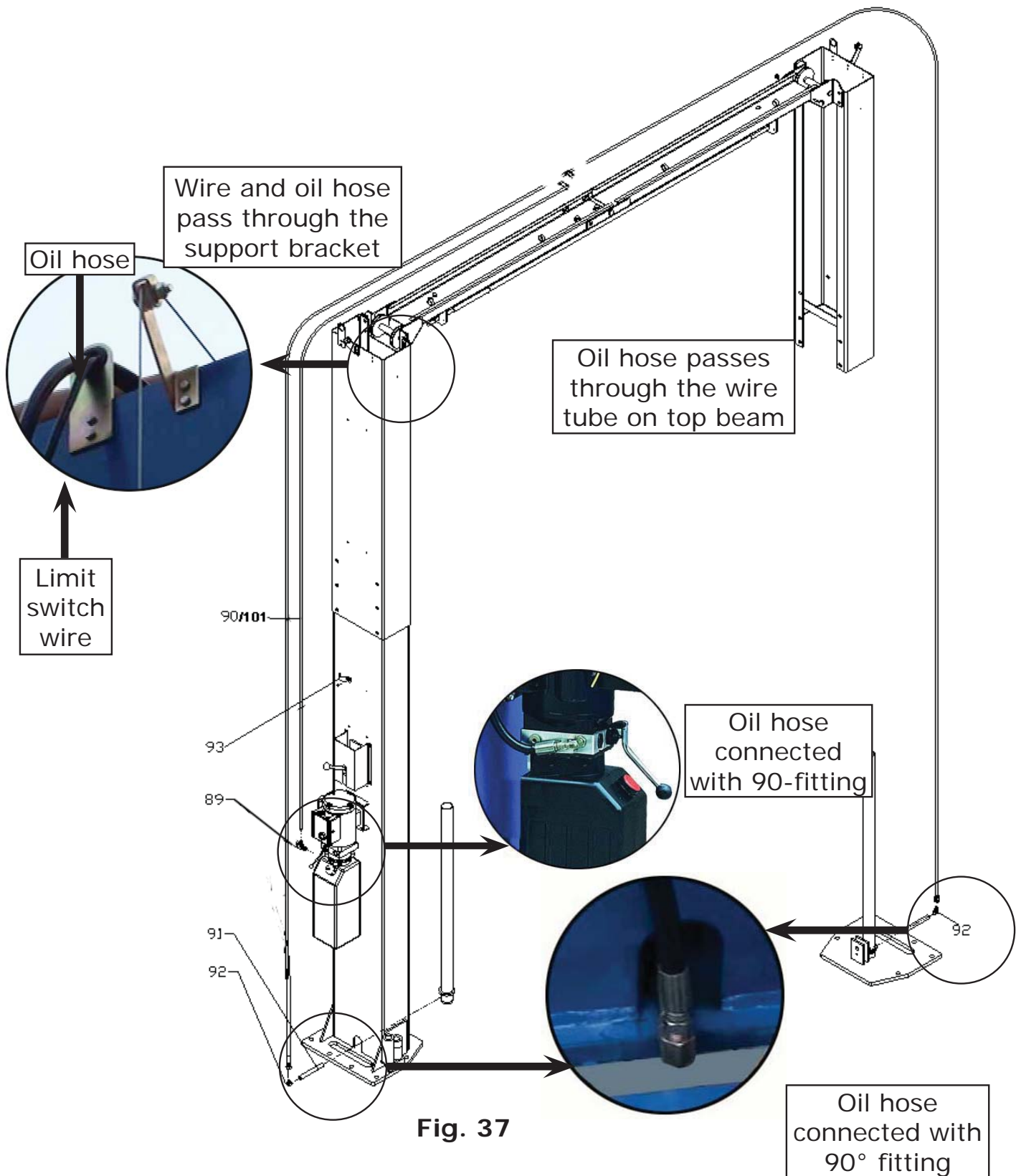

Fig. 36



## N. Install oil hose

At high setting and low setting oil hose connection (See Fig. 37).





## O. Install safety cable.

Install the safety cable from the off side safety assembly to the power side safety assembly and through the top beam (See Fig. 38).

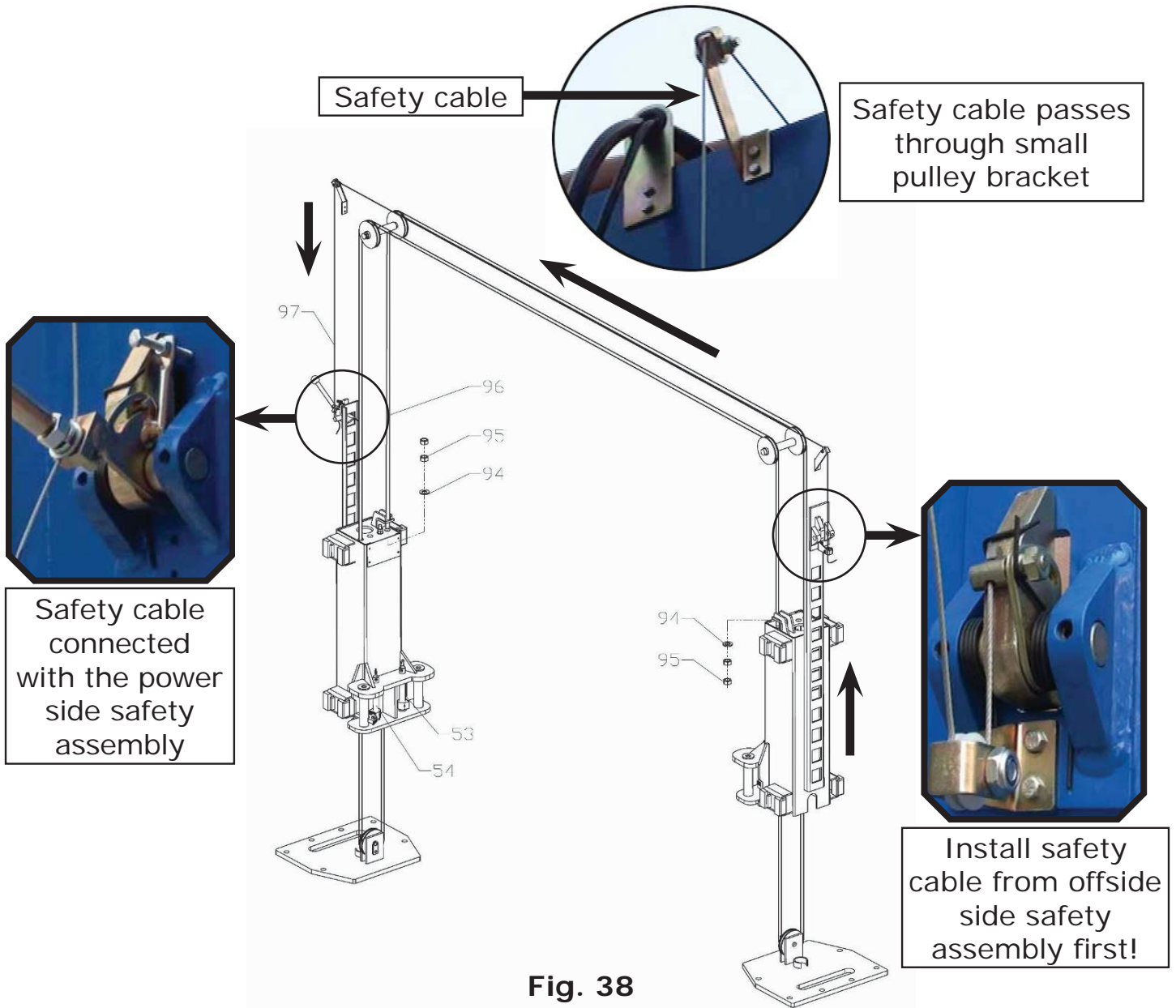

**P. Install hose retainers on both columns (See Fig. 39).**

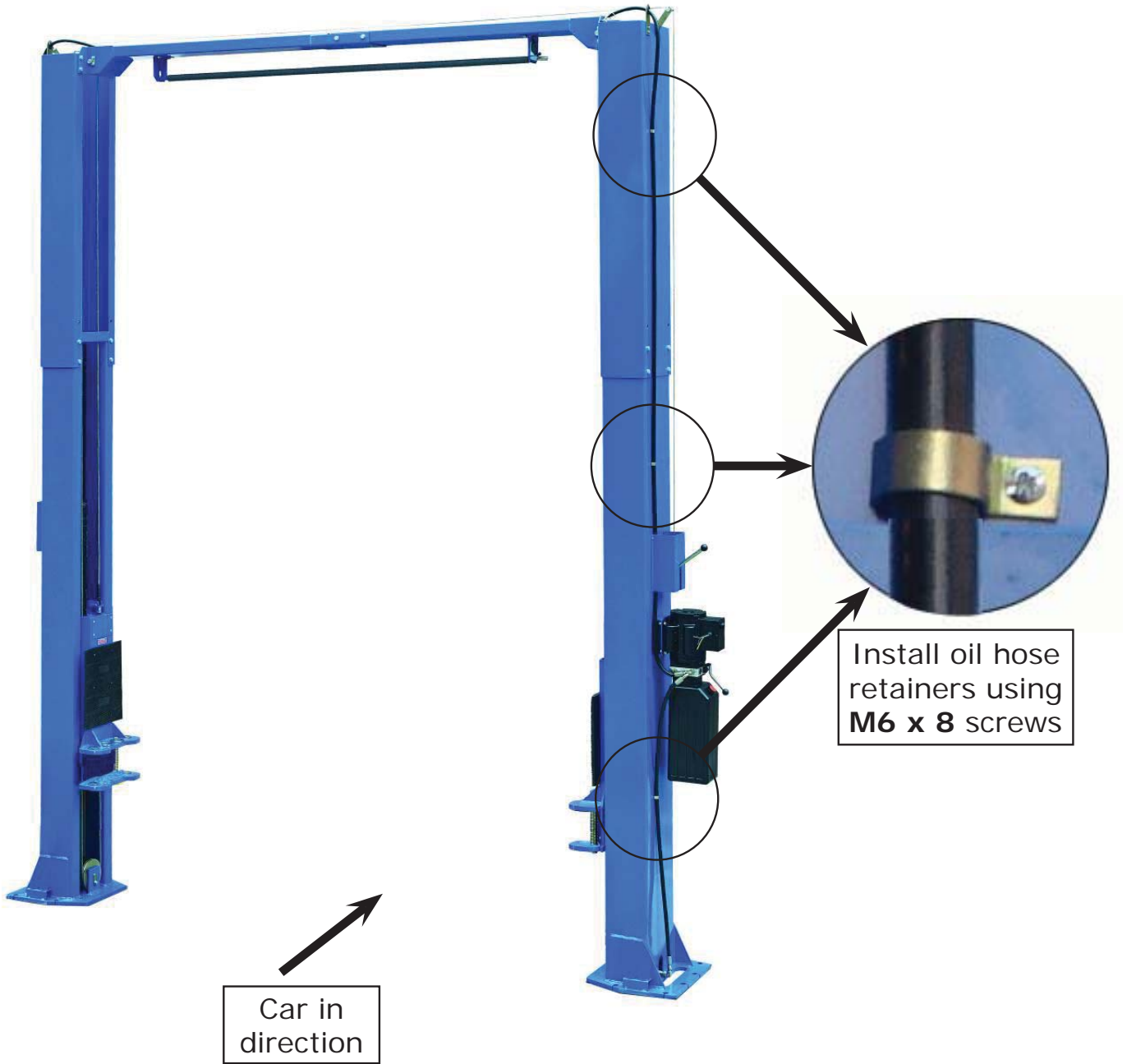

**Fig. 39**

## Q. Install lifting arms and adjust the arm locks.

1. Install lifting arms (See Fig. 40).
2. Lower the carriages down to the lowest position. Use an 8mm Allen wrench to loosen the bolt (See Fig.41).

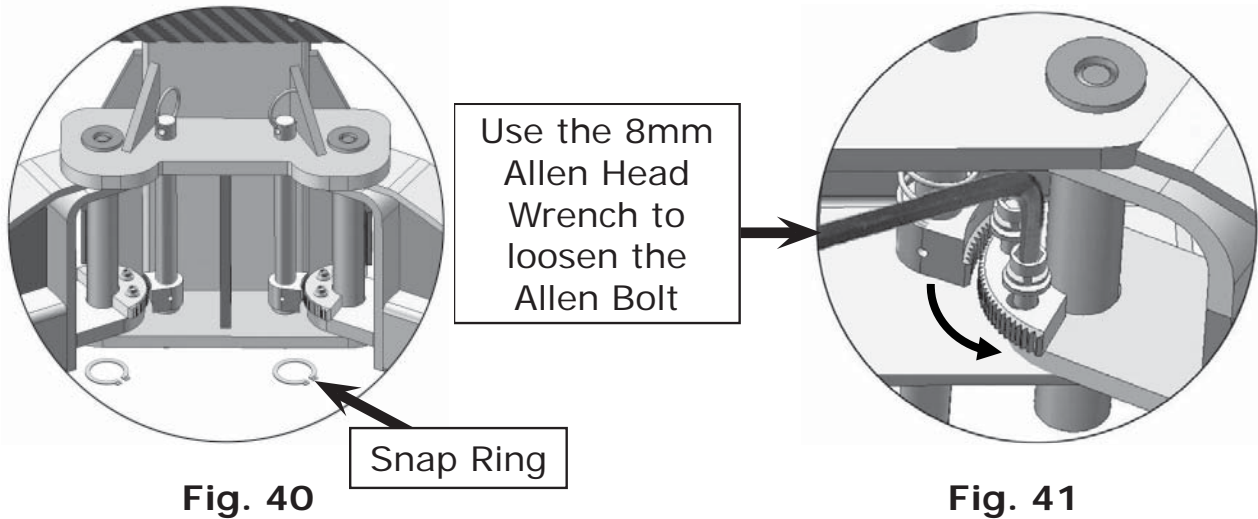

3. Adjust arm lock in direction of arrow (See Fig.42).
4. Adjust moon gear and arm lock until they mesh, then tighten the Allen bolts on the arm lock (See Fig.43).

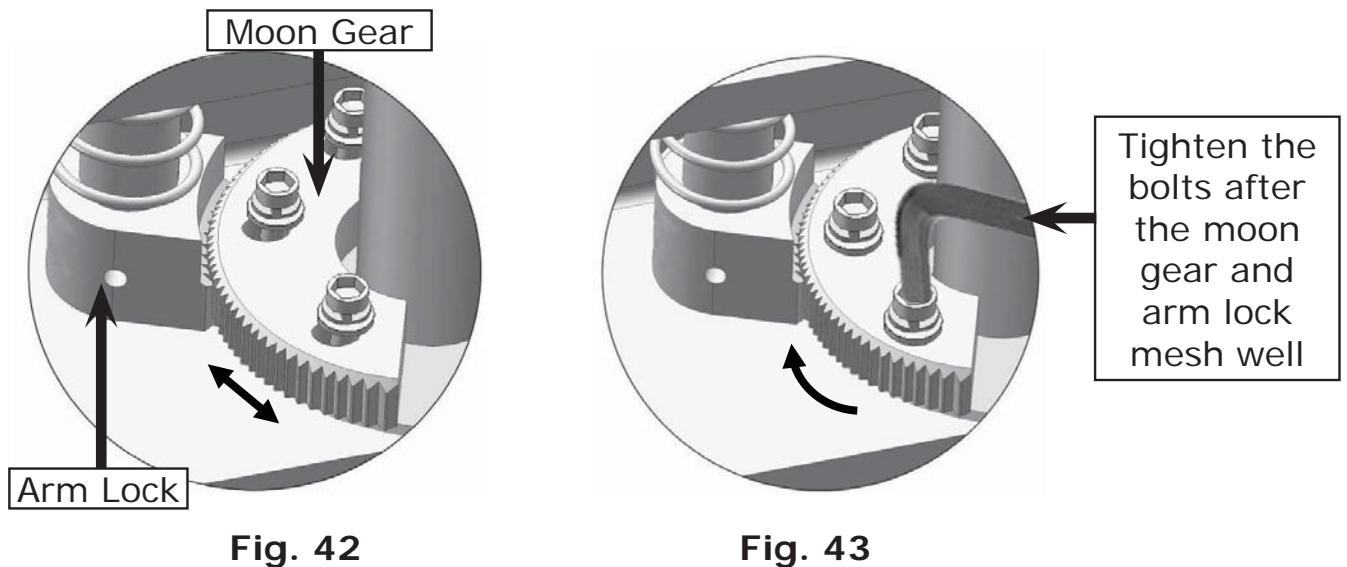

## R. Install Electrical System

Connect the power source according to the data plate on the Power Unit.

**Remove the short “Pig Tail” wire connected to the AC contactor terminals. This wire was used to test the motor after production.**

### ATLAS Single phase motor

**Please Note: This motor is powered by Alternating Current and the terminals on the AC contactor are not wire color specific. There are no positive or negative terminals.**

1. Connect the two power supply (**incoming**) wires (**black & white**) to terminals on the AC contactor marked **L2 & L3**.
2. Connect the two motor wires to terminals on the AC contactor marked **T2, T3**. **These wires are already connected from the factory.**
3. Connect the short wire **A2** to **L3** on the AC contactor. **This wire is already connected from the factory.**
4. Remove the **entire** wire that connects from the **“UP” button** to **A1** on the AC contactor.
5. Connect one of the wires (**does not matter which one**) on the Limit Switch to the **“UP” button** and connect the remaining Limit Switch wire to terminal **A1** on the AC contactor.

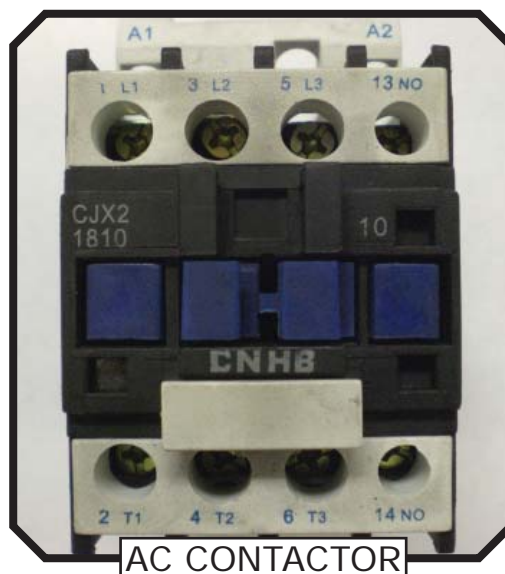

**Fig. 44**

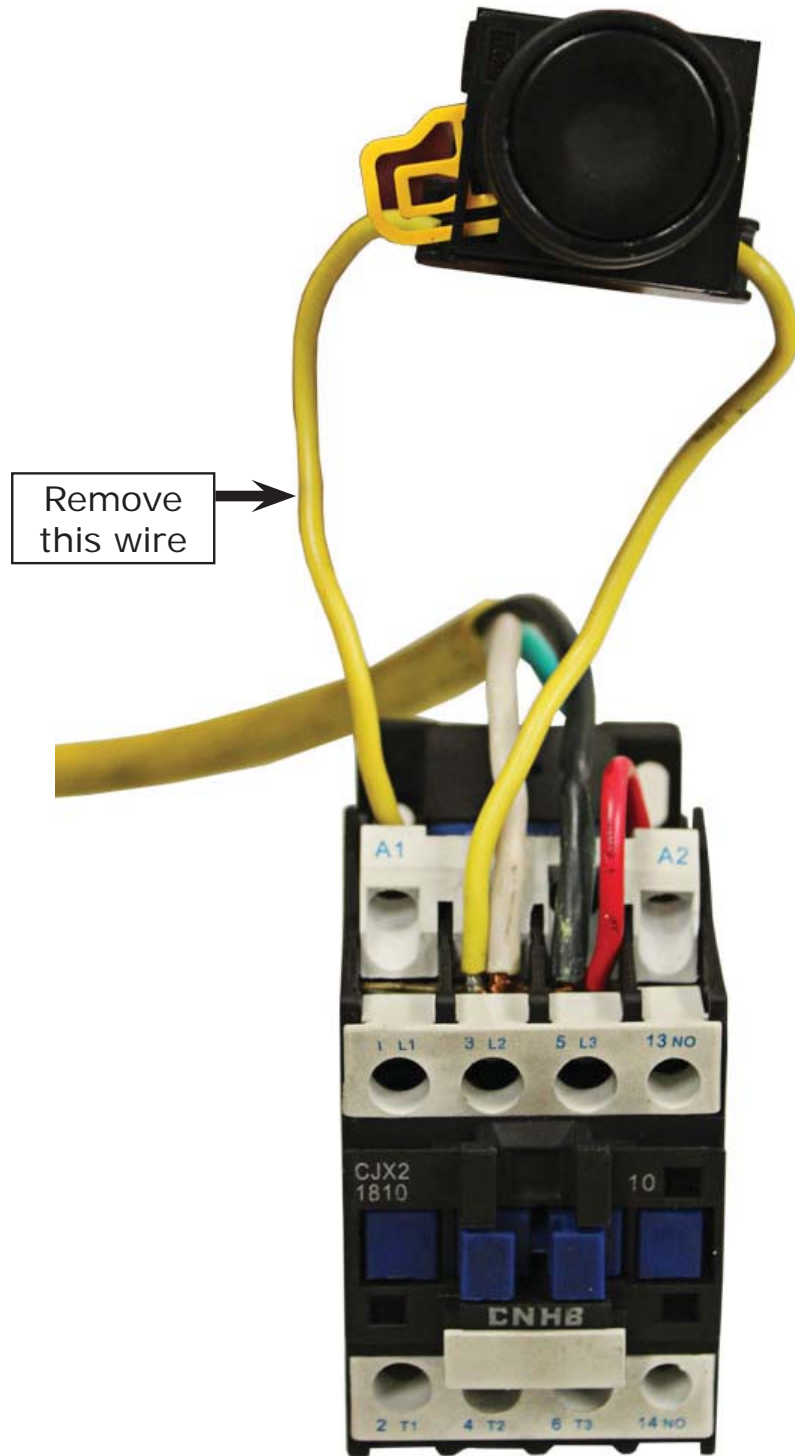

Fig. 45

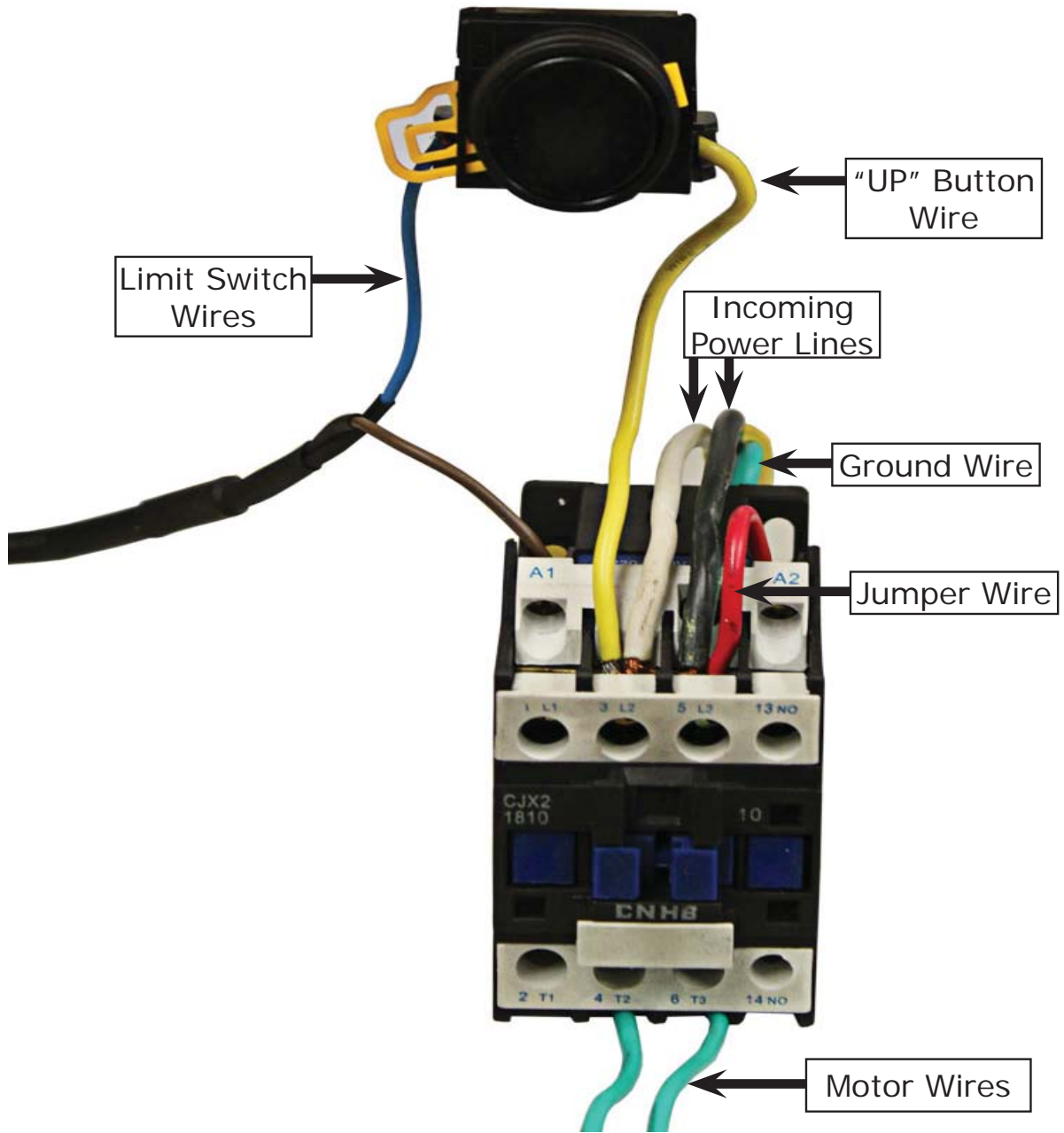

Fig. 46



# Exploded View

Model PV-10PX & PV-10HPX

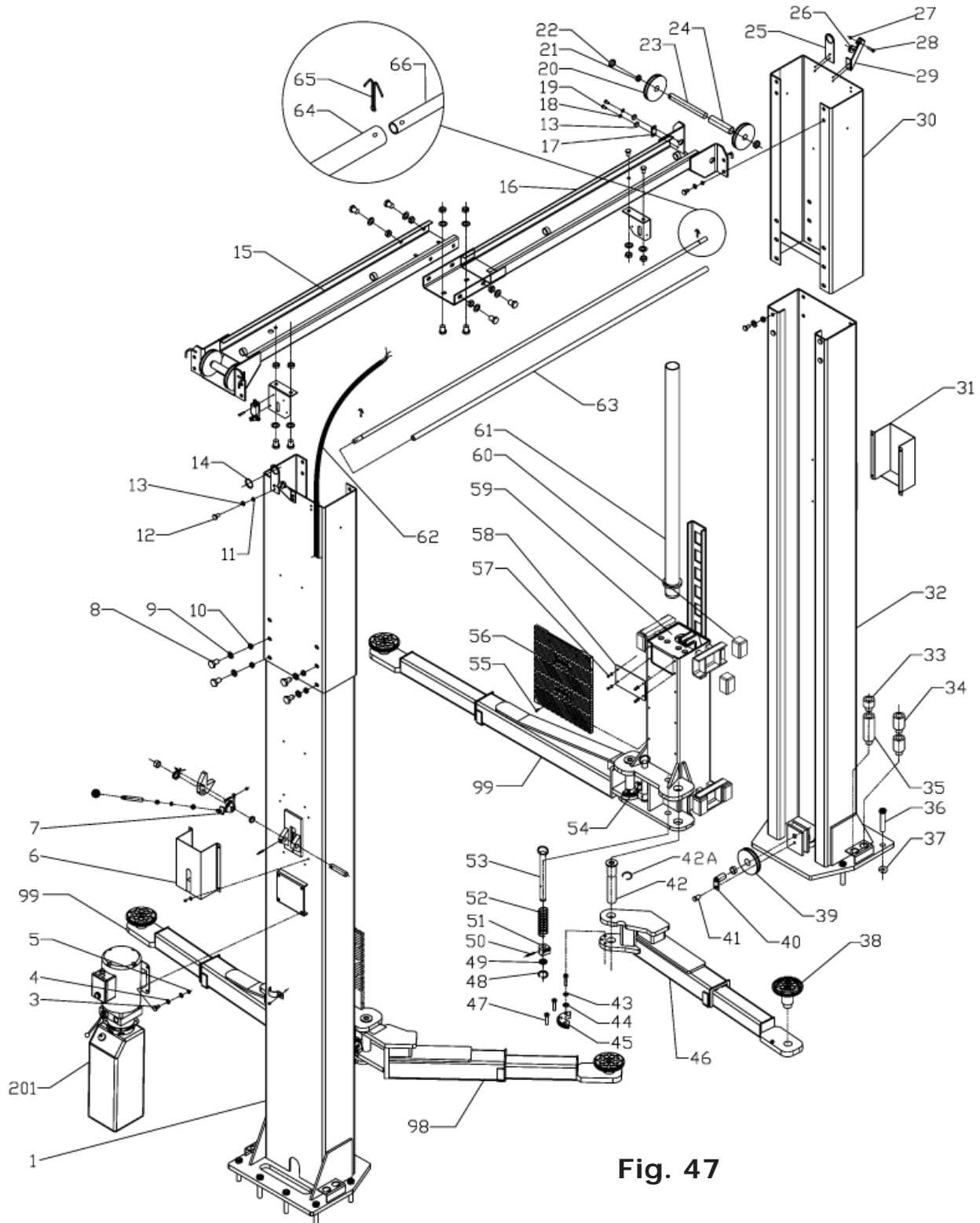

Fig. 47

# Cylinders

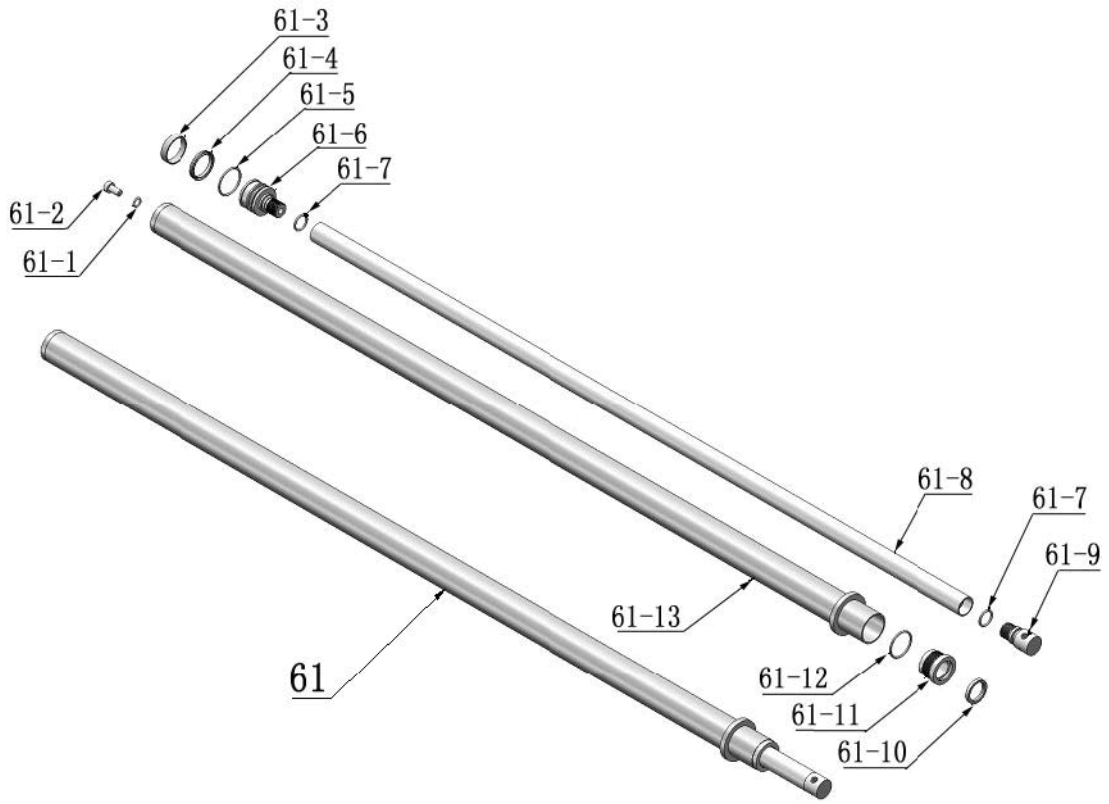
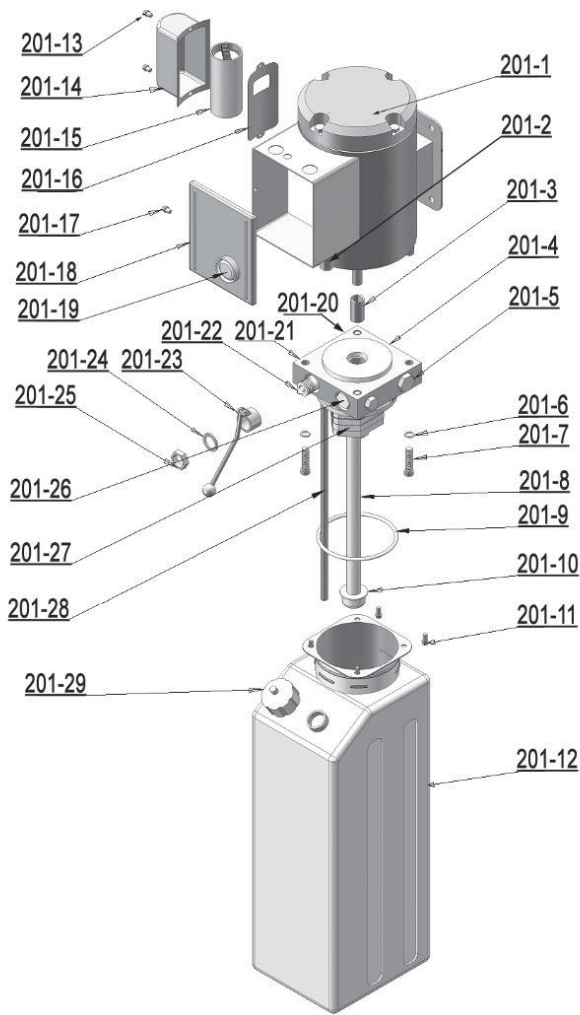

Fig. 48



## Manual Power Units

SPX Manual Power unit  
220V/60HZ, Single phase



**Fig. 49**

ATLAS Manual power unit  
220V/60HZ, Single phase

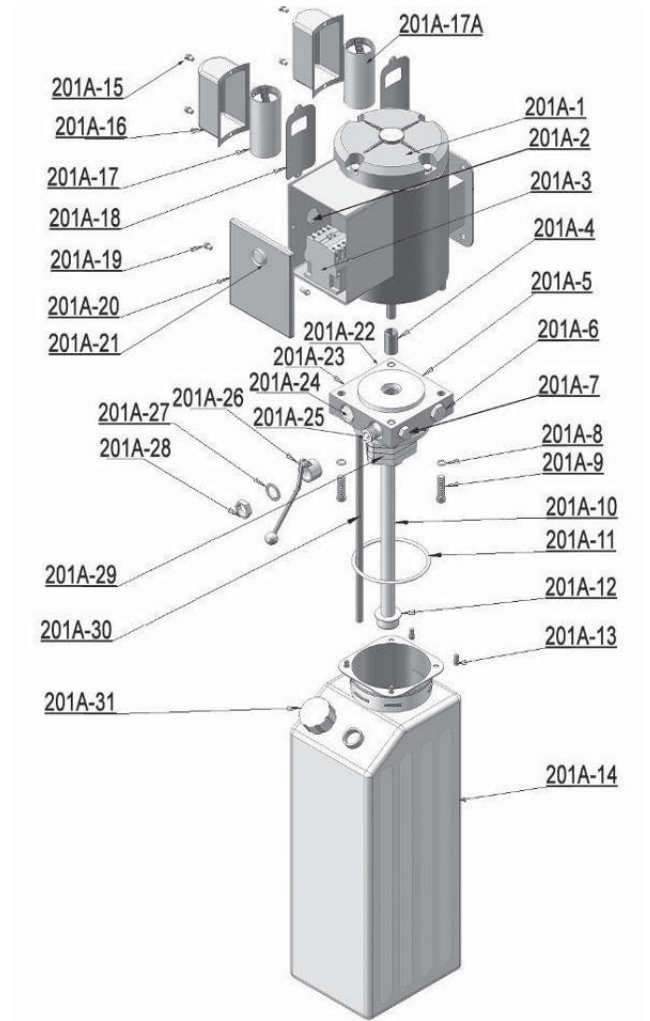

**Fig. 50**

## Illustration of valves for SPX & ATLAS hydraulic power unit

1. SPX manual power unit, 220V/60HZ, Single phase (See Fig. 51).

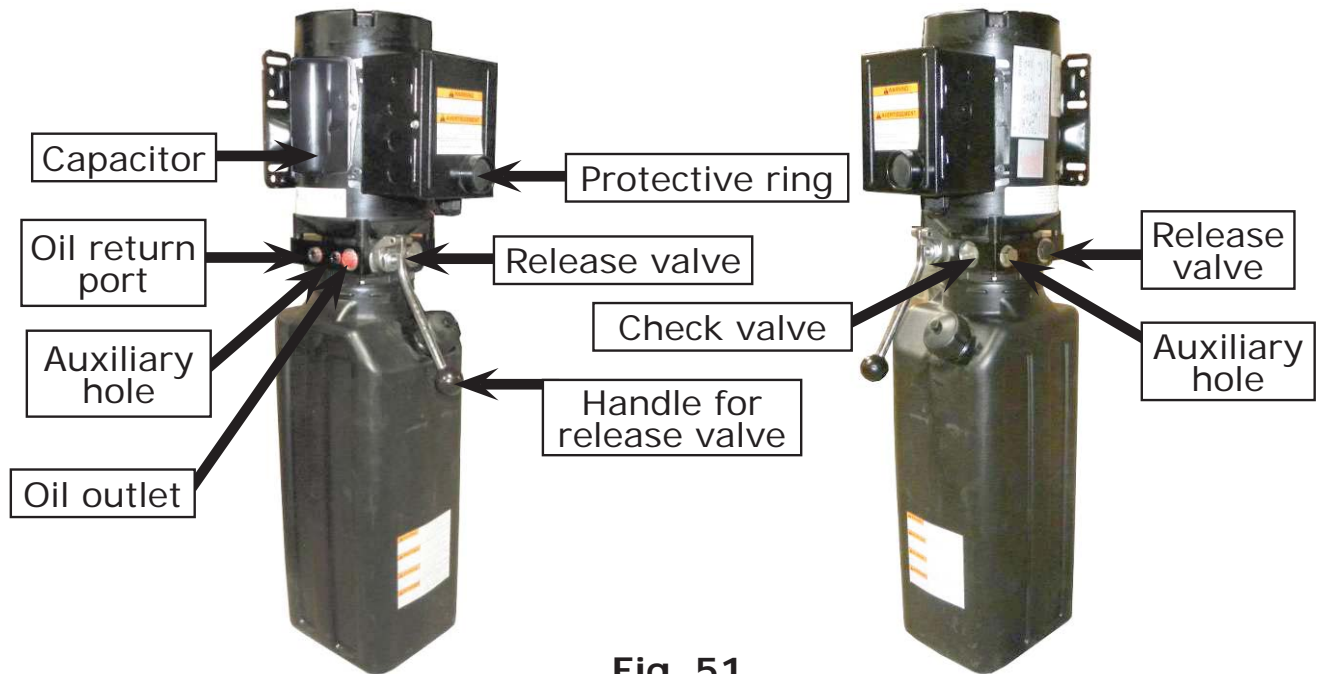

Fig. 51

2. ATLAS manual power unit, 220V/60HZ, Single phase (See Fig. 52).

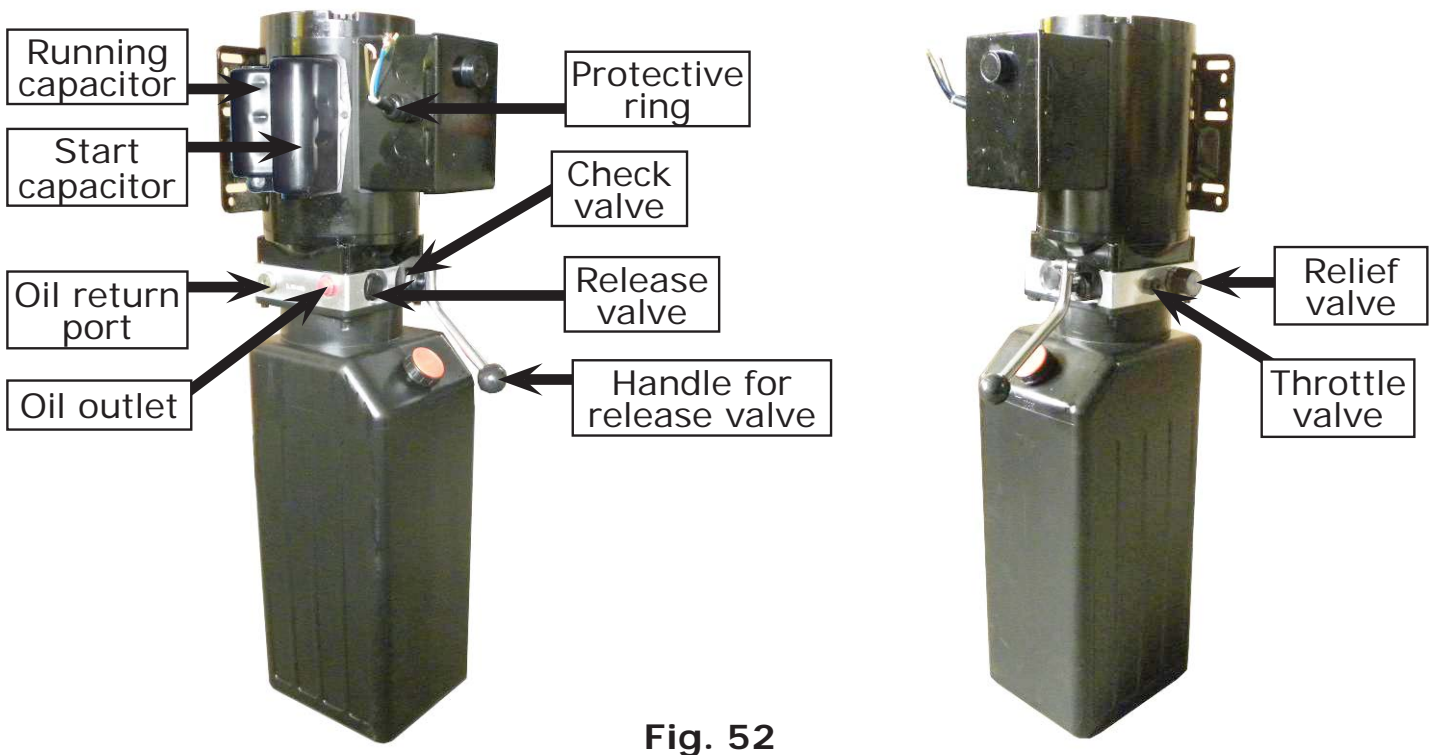

Fig. 52

# Test Run

---

## 1. Adjust the equalizing cables (See Fig. 53).

Use a wrench to hold the cable fitting, meanwhile use a ratchet to tighten the cable nut. Make sure the cables have the same tension so the two carriages lift at the same time. Replace the covers on the carriages.

**If the carriages do not lift at the same time, tighten the cable nut on the lower of the two carriages.**

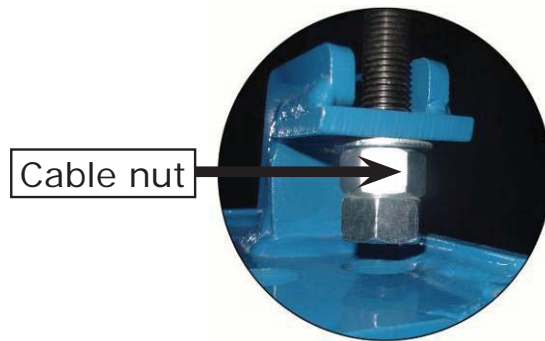

Fig. 53

## 2. Adjust Safety Cable

Lift the carriages and lock at the same height, pull the safety cable and then release a little. Then, tighten the cable nuts. Make sure the safety locks click at the same time.

## 3. Bleeding air

This hydraulic system is designed to bleed air by loosening the bleeding screw. Lift the carriages to about 12 inches and loosen the bleeding plug. Lower the lift until fluid comes out. Tighten the screws after bleeding (See Fig. 54).

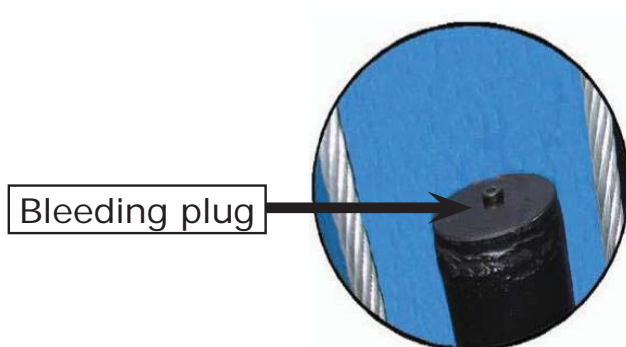

Fig. 54

#### 4. Adjust the lower speed (Only for ATLAS power unit) (Adjust with a load on the lift)

You can adjust the lowering speed of the lift if necessary: Loosen the locking nut on the throttle valve, and then turn the throttle valve clockwise to decrease the lowering speed, or counterclockwise to increase the lowering speed (See Fig. 55).

**Do not forget to tighten the locking nut after the lower speed adjustment has been completed.**

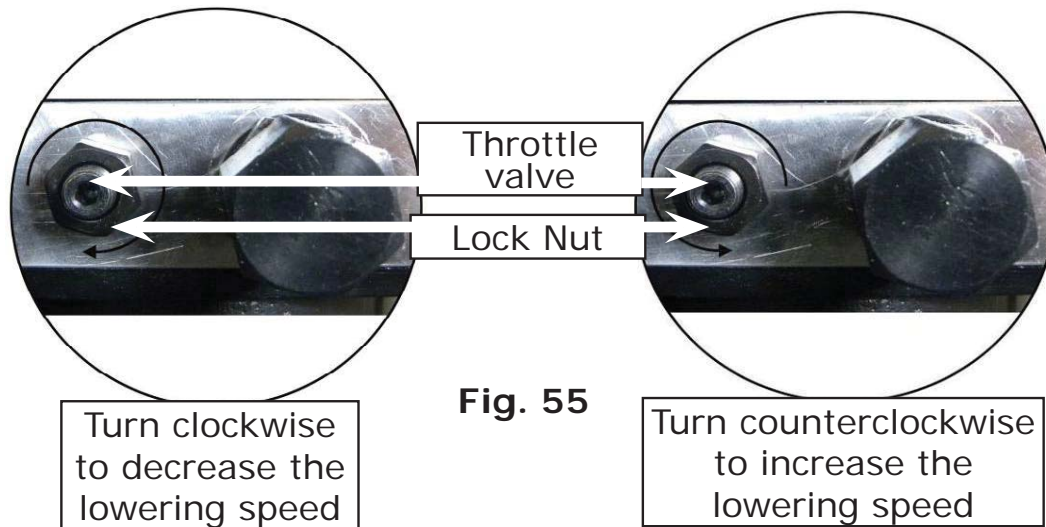

Fig. 55

#### 5. Test with load

After finishing the above adjustment, test run the lift with a load. Run the lift in the low position several times. Run the lift to the top completely.

**NOTE: If the lift vibrated on the way up with a load, lubricate all pulley shafts and wear blocks. If the lift vibrates on the way down, the cylinders need to be bled.**

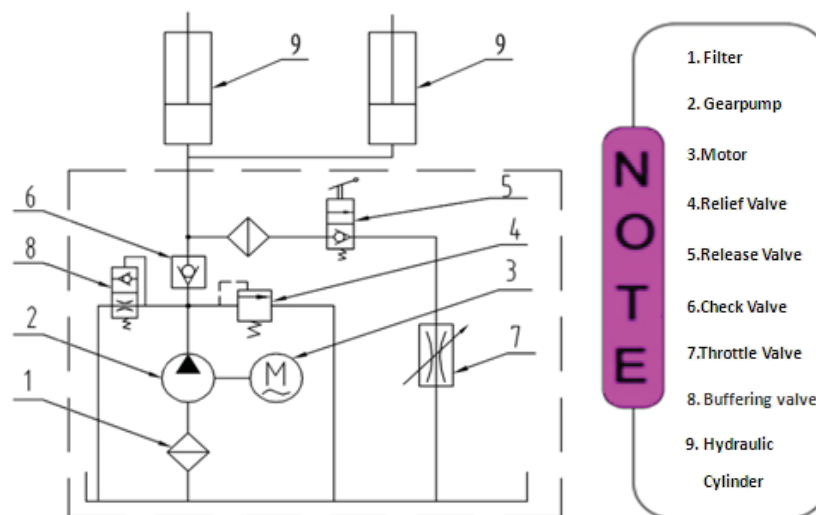

Fig. 56 - Hydraulic System

# Operation Instructions

---

**Please read the safety tips carefully before operating the lift.**

## **To lift vehicle:**

1. Keep the lift area free of clutter;
2. Position lift arms to the lowest position;
3. Open lift arms;
4. Position vehicle between columns;
5. Move arms to the vehicles lifting points;

**NOTE: The four lift arms must make contact at the same time with the vehicle's lifting points and both axles must rise off the ground at the same time.**

6. Press the "UP" button until the lift pads contact the underside of the vehicle. Check to make sure the vehicle is secure;
7. Continue to raise the lift slowly to the desired working height, ensuring the balance of the vehicle;
8. Push lowering handle to lower lift onto the nearest lock. The vehicle is ready to repair.

**NOTE: The lift must always be on the safety locks.**

## **To lower vehicle:**

1. Keep the lift area free of clutter;
2. Press the "UP" button to raise the vehicle slightly, and then release the safety device. Lower the vehicle by pushing the lowering handle;
3. Open the arms and position them to the shortest length;
4. Drive the vehicle away from the lift.

# Maintenance Schedule

---

## Monthly:

1. Re-torque the anchor bolts to 150 Ft Lbs;
2. Check all connectors, bolts and pins to insure proper mounting;
3. Lubricate cable with lubricant;
4. Make a visual inspection of all hydraulic hoses/lines for possible wear or leakage;
5. Check the condition of the safety lock device;
6. Lubricate all rollers and pins with 90wt. Gear oil or equivalent.

**NOTE: All anchor bolts should take full torque. If any of the bolts do not function for any reason, DO NOT use the lift until the bolt has been replaced.**

## Every six months:

1. Make a visual inspection of all moving parts for possible wear, interference or damage;
2. Check and adjust as necessary, equalizer tension of the cables to ensure level lifting;
3. Check columns for plumb;
4. Check rubber pads and replace as necessary;
5. Check safety lock device and make sure the condition is suitable.

# Trouble Shooting

---

TROUBLE	CAUSE	REMEDY
Motor does not run	<ol style="list-style-type: none"> <li>1. Button does not work</li> <li>2. Wiring connections are not in good condition</li> <li>3. Motor burned out</li> <li>4. Height Limit Switch is damaged</li> <li>5. AC contactor burned out</li> </ol>	<ol style="list-style-type: none"> <li>1. Replace button</li> <li>2. Repair all wiring connections</li> <li>3. Repair or replace motor</li> <li>4. Replace the Limit Switch</li> <li>5. Replace AC Contactor</li> </ol>
Motor runs but the lift is not raised	<ol style="list-style-type: none"> <li>1. Motor runs in reverse rotation</li> <li>2. Gear Pump out of operation</li> <li>3. Release Valve in damage</li> <li>4. Relief Valve or Check Valve in damage</li> <li>5. Low oil level</li> </ol>	<ol style="list-style-type: none"> <li>1. Reverse two power wire</li> <li>2. Repair or replace</li> <li>3. Repair or replace</li> <li>4. Repair or replace</li> <li>5. Fill tank</li> </ol>
Lift does not stay up	<ol style="list-style-type: none"> <li>1. Release Valve out of work</li> <li>2. Relief Valve or Check Valve leakage</li> <li>3. Cylinder or Fittings leaks</li> </ol>	Repair or replace
Lift raises slowly	<ol style="list-style-type: none"> <li>1. Oil line is jammed</li> <li>2. Motor running on low voltage</li> <li>3. Oil mixed with air</li> <li>4. Gear Pump leaks</li> <li>5. Overload lifting</li> </ol>	<ol style="list-style-type: none"> <li>1. Clean the oil line</li> <li>2. Check Electrical System</li> <li>3. Fill tank</li> <li>4. Replace Pump</li> <li>5. Check load</li> </ol>
Lift will not lower	<ol style="list-style-type: none"> <li>1. Safety device are in activated</li> <li>2. Release Valve in damage</li> <li>3. Safety cable broken</li> <li>4. Oil system is jammed</li> </ol>	<ol style="list-style-type: none"> <li>1. Release the safeties</li> <li>2. Repair or replace</li> <li>3. Replace</li> <li>4. Clean the oil system</li> </ol>



# PV-10PX and PV-10HPX Parts List

---

Item	Part#	Description	Qty.		Note
			PV-10PX	PV-10HPX	
1	217001B	Powerside column	1	1	
201	209002	Manual Power unit	1	1	
3	209003	Bolt	4	4	
4	209033	Lock washer	4	4	
5	209005	Nut	4	4	
6	217003	Powerside lock cover	1	1	
7	217004	Main cam lock	1	1	
8	217069	Bolt	34	34	
9	206006	Washer	35	35	
10	206023	Self locking nut	34	34	
11	420018	Self locking nut	8	8	
12	217013	Bolt	8	8	
13	420045	Washer	26	26	
14	217025	Protective ring	2	2	
15	217169	Right overhead bar	1	1	
16	217170	Left overhead bar	1	1	
17	420044	Pin stop	2	2	
18	209149	Washer	8	8	
19	420138	Bolt	4	4	
20	217019	Top pulley	4	4	
21	217020	Bronze bush for pulley	6	6	
22	217021	Top pulley spacer	4	4	
23	217022	Pin	2	2	
24	217023	Pin spacer	2	2	
25	217024	Hose support	2	2	
26	206009	Plastic small pulley	3	3	
27	209056	Self locking nut	3	3	
28	209046	Bolt	3	3	
29	217026	Safety cable bracket	2	2	
30	217027	Extension column	2	0	
	217027A		0	2	

Item	Part#	Description	Qty.		Note
			PV-10PX	PV-10HPX	
31	217028	Offside lock cover	1	1	
32	217034B	Offside column	1	1	
33	209051B	Adapter 1.5"	4	4	
34	209052B	Adapter 2.5"	4	4	
35	209053B	Adapter 5"	4	4	
36	209059B	Anchor bolt	12	12	
37	620065	Shim	10	10	
38	217114A	Rubber pad assy.	4	4	
38A	420138	Socket bolt	4	4	
38B	209134	Rubber Pad	4	4	
38C	680030B	Rubber Pad frame	4	4	
39	217036	Bottom pulley	2	2	
40	217037	Bottom pin	2	2	
41	209038	Bolt	6	6	
42	217168	Arm pin	4	4	
42A	520023	Snap ring	4	4	
43	209039	Lock washer	18	18	
44	209022	Washer	18	18	
45	206049	Moon gear	4	4	
46	217041A	Left front arm	1	1	
46A	217115	Left front outer arm	1	1	
46B	217116A	Left front inner arm	1	1	
47	206048	Allen bolt	12	12	
48	206032	C-clip	4	4	
49	217043	Limit ring	4	4	
50	206036	Roll pin	4	4	
51	217044	Arm lock	4	4	
52	217045	Spring	4	4	
53	217046A	Left arm lock bar	2	2	
54	217046	Right arm lock bar	2	2	
55	209019	Flat head screw	12	12	
56	217053	Protective Rubber	2	2	
57	209009	Cup head bolt	26	26	
58	217054	Carriage plastic cover	2	2	
59	217197	Carriage	2	2	
60	217188	Slider block	16	16	
61	217056	Cylinder	2	2	
62	217171	Wire cable	1	0	
	217172	Wire cable	0	1	

Item	Part#	Description	Qty.		Note
			PV-10PX	PV-10HPX	
63	206025A	Foam Cushion	1	1	
64	206129	Limit bar	1	1	
65	201005	Split Pin	2	2	
66	206025C	Limit bar link	2	2	
67	206013	Limit switch	1	1	
68	206011	Cup head bolt	2	2	
69	206042	Limit bar bracket	2	2	
70	420026	Lock washer	1	1	
71	206023A	Nut	1	1	
72	217005	Plastic ball	1	1	
73	217006	Lock handle	1	1	
74	217007	Large spacer	2	2	
75	217030	Main spring	2	2	
76	217009	Main lock	2	2	
77	217010	Bolt	1	1	
78	217011	Nut	1	1	
79	217012	Small spacer	2	2	
80	217050	Main lock pin	2	2	
81	217051	Screw	2	2	
82	217066	Bolt	2	2	
83	217008	Torsion spring	1	1	
84	217031	Cam lock	1	1	
85	217033	Self locking nut	1	1	
86	217032	Cable lock hold	1	1	
87	217029	Small pulley bracket	1	1	
88	217199	Oil hose	2	0	
	217201		0	2	
89	209060	90 fitting for power unit	1	1	
90	217200	Oil hose	1	0	
91	217060	Extend fitting for cylinder	2	2	
92	217198	90 Fitting	2	2	
93	217191	Hose clamp	10	10	
94	420029	Cable nut washer	4	4	
95	209066	Cable nut	8	8	
96	217063	Cable	2	0	
	217063A		0	2	
97	217064	Safety cable	1	0	
	217064A		0	1	
98	217042A	Right front arm	1	1	

Item	Part#	Description	Qty.		Note
			PV-10PX	PV-10HPX	
98A	217117	Right front outer arm	1	1	
98B	217116A	Right front inner arm	1	1	
99	217049A	Rear arm	2	2	
99A	217118	Rear outer arm	2	2	
99B	217119A	Rear inner arm	2	2	
100	217500B	Parts box	1	0	
	217503B		0	1	
101	217202	Oil hose	0	1	
102	217146A	Optional cable L=10144mm	0	2	
103	201090	Shim	10	10	
104	211016	T-FITTING	1	1	

Item	Part#	Description	Qty.		Note
			PV-10PX	PV-10HPX	
<b>Parts For Hydraulic Cylinder</b>					
61-1	209069	O-Ring	2	2	
61-2	209070	Bleeding Plug	2	2	
61-3	209071	Support Ring	2	2	
61-4	209072	Y-Ring	2	2	
61-5	209073	O-Ring	2	2	
61-6	209074	Piston	2	2	
61-7	209075	O-Ring	4	4	
61-8	217076	Piston rod	2	2	
61-9	209077	Piston rod fitting	2	2	
61-10	209078	Dust ring	2	2	
61-11	209079	Head cap	2	2	
61-12	209080	O-Ring	2	2	
61-13	209081A	Bore weldment	2	2	

Item	Part#	Description	Qty.		Note
			PV-10PX	PV-10HPX	
<b>Parts for Atlas Manual Power Unit, 220V/60Hz, 1 phase</b>					
201A-1	209082A	Motor	1	1	
201A-2	209109	Protective Ring	1	1	
201A-3	209112	AC contactor	1	1	
201A-4	209083A	Motor Connecting Shaft	1	1	
201A-5	209084A	Valve Body	1	1	
201A-6	209085A	Relief Valve	1	1	
201A-7	209113	Throttle Valve	1	1	
201A-8	209086A	Lock Washer	4	4	
201A-9	209087A	Socket Bolt	4	4	
201A-10	209088A	Inlet Pipe	1	1	
201A-11	209089A	O-Ring	1	1	
201A-12	209090A	Filter	1	1	
201A-13	209091A	Socket Bolt	4	4	
201A-14	209092A	Reservoir (10liter)	1	1	
201A-15	209093A	Cup Head Bolt with washer	4	4	
201A-16	209094A	Cover of Capacitor	2	2	
201A-17	209095A	Start Capacitor	1	1	
201A-17A	209095B	Run Capacitor	1	1	
201A-18	209096A	Rubber Gasket	2	2	
201A-19	209097A	Cup Head Bolt with washer	2	2	
201A-20	209098A	Cover of Motor Terminal Box	1	1	
201A-21	209099A	Push Button	1	1	
201A-22	209110A	Oil Return Port	1	1	
201A-23	209100A	Oil Outlet	1	1	
201A-24	209105A	Check Valve	1	1	
201A-25	209101A	Release Valve	1	1	
201A-26	209102A	Handle For Release Valve	1	1	
201A-27	209103A	Washer	1	1	
201A-28	209104A	Hex Nut	1	1	
201A-29	209106A	Gear Pump	1	1	
201A-30	209107A	Oil Return Pipe	1	1	
201A-31	209108A	Filler Cap	1	1	

# Warranty

---



**This item** is warranted for five (5) years on structural components, two (2) years on hydraulic cylinders, and one (1) year on electric or air / hydraulic power units from invoice date. Wear items are covered by a 90 day warranty.

Our LIMITED warranty policy does **not include a labor** warranty. Our products are sold at such a competitive price that Greg Smith Equipment cannot afford to send technicians into the field to repair the Atlas® automotive lifts. We assume that the buyer of our automotive lifts is mechanically inclined or has employees that are mechanically inclined to perform essential repair services and or maintenance. We also have a list of service technicians that can come to your facility/house at the customer's expense.

**NOTE: ALL WARRANTY CLAIMS MUST BE PRE-APPROVED BY THE MANUFACTURER TO BE VALID.**

The Manufacturer shall repair or replace at their option for this period those parts returned to the factory freight prepaid, which prove after inspection to be defective. This warranty will not apply unless the product is installed, used and maintained in accordance with the Manufacturers installation, operation and maintenance instructions.

This warranty applies to the ORIGINAL purchaser only, and is non-transferable. The warranty covers the products to be free of defects in material and workmanship but, does not cover normal maintenance or adjustments, damage or malfunction caused by: improper handling, installation, abuse, misuse, negligence, carelessness of operation or normal wear and tear. In addition, this warranty does not cover equipment when repairs or alterations have been made or attempted to the Manufacturer's products.

THIS WARRANTY IS EXCLUSIVE AND IS LIEU OF ALL OTHER WARRANTIES EXPRESSED OR IMPLIED INCLUDING ANY IMPLIED WARRANTY OR MERCHANTABILITY OR ANY IMPLIED WARRANTY OF FITNESS FROM A PARTICULAR PURPOSE, AND ALL SUCH IMPLIED WARRANTIES ARE EXPRESSLY EXCLUDED.

THE REMEDIES DESCRIBED ARE EXCLUSIVE AND IN NO EVENT SHALL THE MANUFACTURER, NOR ANY SALES AGENT OR OTHER COMPANY AFFILIATED WITH IT OR THEM, BE LIABLE FOR SPECIAL CONSEQUENTIAL OR INCIDENTAL DAMAGES FOR THE BREACH OF OR DELAY IN PERFORMANCE OF THIS WARRANTY. THIS INCLUDES, BUT IS NOT LIMITED TO, LOSS OF PROFIT, RENTAL OR SUBSTITUTE EQUIPMENT OR OTHER COMMERCIAL LOSS.

The warranty shall be governed under the laws of Indiana, and shall be subject to the exclusive jurisdiction of the Court in the State of Indiana in the county of Marion.

**PRICES:** Prices and specifications are subject to change without notice. All orders will be invoiced at prices prevailing at time of shipment. Prices do not include any local, state or federal taxes.

**RETURNS:** Products may not be returned without prior written approval from the Manufacturer.

DUE TO THE COMPETITIVENESS OF THE SELLING PRICE OF THESE LIFTS, THIS WARRANTY POLICY WILL BE STRICTLY ADMINISTERED AND ADHERED TO.